



The author(s) shown below used Federal funding provided by the U.S. Department of Justice to prepare the following resource:

Document Title: Live Fast, Die Young: Anticipated Early Death and Adolescent Violence and Gang Involvement

Author(s): Arna L. Carlock

Document Number: 250425

Date Received: December 2016

Award Number: 2014-IJ-CX-0008

This resource has not been published by the U.S. Department of Justice. This resource is being made publically available through the Office of Justice Programs' National Criminal Justice Reference Service.

Opinions or points of view expressed are those of the author(s) and do not necessarily reflect the official position or policies of the U.S. Department of Justice.

Live Fast, Die Young: -
Anticipated Early Death and -
Adolescent Violence and Gang Involvement -

by

Arna L. Carlock

A Dissertation -
Submitted to the University at Albany, State University of New York -
in Partial Fulfillment of -
the Requirements for the Degree of -
Doctor of Philosophy -

School of Criminal Justice -

2016 -

Live Fast, Die Young: -
Anticipated Early Death and -
Adolescent Violence and Gang Involvement -

by

Arna L. Carlock

COPYRIGHT 2016 -

Abstract

Strategies employed by criminal justice agencies to reduce offending often focus on deterrence, with policies relying on the threat of punishment to discourage individuals from crime. However, such strategies will fail if individuals do not fear these consequences, or when potential rewards of offending outweigh the risks. According to life history theory, adolescents with a dangerous or unpredictable childhood environment discount the future and engage in risky behaviors because they have little to lose. Many adolescents embody this “live fast, die young” mentality, particularly those already at risk of delinquency due to other factors. The scientific literature refers to this mindset as fatalism, future discounting, or anticipated early death (AED). Despite the indication that AED is a crucial correlate of delinquent activity, only recently have criminologists begun to directly examine the relationship. To address this gap in the literature, this dissertation analyzes two longitudinal datasets. One dataset, the National Longitudinal Study of Adolescent Health (Add Health), offers a nationally representative sample, while the Rochester Youth Development Study (RYDS) provides a sample of at-risk youth in Rochester, New York. Structural equation modeling quantifies adolescent AED in each dataset. The use of two data sources strengthens the reliability and validity of the latent variable’s measurement. I study the effects of the latent AED measures on adolescent violence and gang activity, finding that higher levels of AED correspond to a greater likelihood of violence and gang activity, with the relationships often mediated by low self-control. In an attempt to determine the causal ordering of AED and risk-taking behaviors, I exploit the longitudinal nature of the RYDS data by estimating autoregressive cross-lagged panel models. Findings lend support to life history theory’s assumption that AED predicts risk-taking behavior; I find little evidence that violence or gang activity cause AED.

Acknowledgments

To avoid making this list of those to whom I owe gratitude overly long, I will instead make it grievously short: Thank you to the family, friends, and faculty who have supported me along the way.

Funding Acknowledgments

This dissertation was supported by the National Institute of Justice Graduate Research Fellowship 2014-IJ-CX-0008 and the University at Albany Initiatives for Women.

This research uses data from Add Health, a program project directed by Kathleen Mullan Harris and designed by J. Richard Udry, Peter S. Bearman, and Kathleen Mullan Harris at the University of North Carolina at Chapel Hill, and funded by grant P01-HD31921 from the Eunice Kennedy Shriver National Institute of Child Health and Human Development, with cooperative funding from 23 other federal agencies and foundations. Special acknowledgment is due Ronald R. Rindfuss and Barbara Entwisle for assistance in the original design. Information on how to obtain the Add Health data files is available on the Add Health website (<http://www.cpc.unc.edu/addhealth>). No direct support was received from grant P01-HD31921 for this analysis.

This research also uses data from the Rochester Youth Development Study (RYDS). Support for the Rochester Youth Development Study has been provided by the Office of Juvenile Justice and Delinquency Prevention (86-JN-CX-0007), the National Institute on Drug Abuse (R01DA005512), and the National Science Foundation (SBR-9123299). Work on this project was also aided by grants to the Center for Social and Demographic Analysis at the University at Albany from NICHD (P30HD32041) and NSF (SBR-9512290).

Points of view or opinions in this document are those of the author and do not necessarily represent the official position or policies of the funding agencies.

TABLE OF CONTENTS

List of Figures	ix
List of Tables	x
CHAPTER 1	1
Introduction	1
CHAPTER 2	4
Theoretical Framework and Literature Review	4
Life History Theory and Future Discounting.....	4 -
Review of the Literature	9 -
Anticipated early death.	9 -
Gangs and violence.	21 -
Self-control.	26 -
Current Study	28 -
Theoretical Model.....	30 -
CHAPTER 3	38
Methods	38
Data and Samples.....	38 -
The National Longitudinal Study of Adolescent Health (Add Health).	38 -
The Rochester Youth Development Study (RYDS).	40 -
Analytical Approach	41 -
Objective 1: Operationalize a quantifiable measure of AED.....	41 -
Objective 2: Examine the impact of AED on individual violence and gang activity.	44 -
Objective 3: Determine the causal ordering of AED and delinquent risk-taking -	
behaviors (i.e., violence and gang activity).	45 -

Observed Variables.....	47 -
Missing Data and Structural Equation Modeling.....	53 -
Available case analysis with robust weighted least squares.	54 -
Summary.....	56 -
CHAPTER 4.....	62
Measurement of Anticipated Early Death.....	62
Add Health.....	63 -
Second-order factor analysis exemplar.	63 -
Differences by sex.....	66 -
Evaluation of reliability and validity.	67 -
RYDS.....	70 -
Second-order factor analysis.....	70 -
Differences by sex.....	71 -
Evaluation of reliability and validity.	71 -
Summary.....	72 -
CHAPTER 5.....	82
AED and Violent Behavior.....	82
Add Health.....	82 -
Violence prevalence.....	82 -
AED measurement revisited.	86 -
RYDS.....	87 -
Violence prevalence.....	88 -
Violence variety.....	91 -
AED measurement revisited.	93 -

Summary	96 -
CHAPTER 6	107
AED and Gang Membership.....	107
Gang Membership.....	107 -
Differences by sex.....	109 -
Duration of Gang Membership	111 -
Stability of Gang Membership.....	113 -
Summary.....	114 -
CHAPTER 7	121
Autoregressive Cross-Lagged Panel Models	121
AED and Violence Prevalence.....	122 -
Differences by sex.....	124 -
AED and Gang Membership.....	126 -
Differences by sex.....	127 -
Summary	128 -
CHAPTER 8	134
Summary and Discussion	134
Study Overview	134 -
Summary of Results.....	137 -
Measurement of AED.	137 -
AED and violence.	138 -
AED and gang membership.....	139 -
Causal ordering of AED and risk-taking behavior.	141 -
Implications.....	143 -

Limitations and Future Research	146 -
Theory	146 -
Measurement	148 -
Conclusion	150 -
REFERENCES.....	151
APPENDIX A	163
Coding of Project Variables by Dataset.....	163
APPENDIX B	168
RYDS Observed Variables Descriptive Statistics	168
APPENDIX C	172
Comparisons of RYDS Male and Female SEM Coefficients (z scores).....	172

List of Figures

Figure 2.1. Theoretical Model of AED, Violence, and Reproductive Behavior	36 -
Figure 2.2. Cross-Lagged Model of AED and Risk-Taking Behavior	37 -
Figure 4.1. Second-Order Measurement Model	74 -
Figure 7.1. Autoregressive Cross-Lagged Panel Model of AED and Violence Prevalence - (Standardized Coefficients)	130 -
Figure 7.2. Autoregressive Cross-Lagged Panel Models of AED and Violence Prevalence by Sex - (Standardized Coefficients)	131 -
Figure 7.3. Autoregressive Cross-Lagged Panel Model of AED and Gang Membership - (Standardized Coefficients)	132 -
Figure 7.4. Autoregressive Cross-Lagged Panel Models of AED and Gang Membership by Sex - (Standardized Coefficients)	133 -

List of Tables

Table 3.1. Demographic Statistics for Add Health and RYDS Samples	58 -
Table 3.2. Add Health Observed Variables Descriptive Statistics, Wave I.....	59 -
Table 4.1. Add Health Wave I AED Measurement Model (Standardized Loadings)	75 -
Table 4.2. Add Health Waves I and II AED Measurement Models (Standardized Loadings).....	76 -
Table 4.3. Add Health AED Measurement by Sex (Standardized Loadings)	77 -
Table 4.4. Correlations of Add Health AED Indirect and Direct Measures with Outcome - Behaviors	78 -
Table 4.5. RYDS AED Measurement Models (Standardized Loadings)	79 -
Table 4.6. RYDS AED Measurement Models by Sex (Standardized Loadings)	80 -
Table 4.7. Correlations of RYDS AED Indirect Measures with Sexual Behaviors	81 -
Table 5.1. Add Health Structural Models of AED and Violence Prevalence (Standardized - Coefficients).....	98 -
Table 5.2. Comparisons of Add Health Male and Female Structural Parameters for Violence - Prevalence (z scores).....	99 -
Table 5.3. Add Health Three-Wave Structural Models of AED, Violence, and Reproductive - Behavior (Standardized Coefficients).....	100 -
Table 5.4. RYDS Structural Models of AED and Violence Prevalence (Standardized - Coefficients).....	101 -
Table 5.5. RYDS Structural Models of AED and Violence Prevalence by Sex (Standardized - Coefficients).....	102 -
Table 5.6. RYDS Structural Models of AED and Violence Variety (Standardized Coefficients) -	103 -

Table 5.7. RYDS Structural Models of AED and Violence Variety by Sex (Standardized - Coefficients).....	104 -
Table 5.8. RYDS Three-Wave Structural Models of AED, Violence, and Number of Sexual - Partners (Standardized Coefficients)	105 -
Table 5.9. RYDS Three-Wave Structural Models of AED, Violence, and Pregnancy - (Standardized Coefficients)	106 -
Table 6.1. Structural Models of AED and Gang Membership (Standardized Coefficients)	117 -
Table 6.2. Structural Models of AED and Gang Membership by Sex (Standardized Coefficients) -	118 -
Table 6.3. Negative Binomial Model Predicting Duration of Gang Membership (Unstandardized - Coefficients).....	119 -
Table 6.4. Multinomial Logistic Regression Predicting Stability of Gang Membership - (Unstandardized Coefficients)	120 -

CHAPTER 1

Introduction

Life is short, so people are often encouraged by friends, family, and pop culture to make the most of the time they have. This sentiment is at the heart of several popular sayings: “*carpe diem*,” “live like you were dying,” and, more recently, “you only live once” (often abbreviated “#YOLO” on the popular social networking sites Twitter and Facebook). These sayings are meant to inspire people to take risks and make time to fulfill their dreams. However, these sayings can have a different connotation for youths living in violent inner-city “war zones” – many individuals in this setting do “live like they were dying,” for this is a real possibility (Brezina, Tekin, & Topalli, 2009; Garbarino, Kostelny, & Dubrow, 1991; Lorion & Saltzman, 1993). This expectation that one will experience a premature death goes by many names: anticipated early death, future uncertainty, fatalism, early death perception, present orientation, short time horizon, hopelessness. These phrases have slightly different connotations but they all describe the basic feeling that the future is not guaranteed. Uncertainty about the future often results in risky behavior because the immediate payoff is weighed more heavily than potential negative consequences to be faced at a later time. This process is called future discounting. According to life history theory, a theory in evolutionary biology and developmental psychology, adolescents who experience future uncertainty are more likely to engage in risky behaviors because this increases the likelihood of procreation – every organism’s ultimate biological goal.

The purpose of this dissertation is the study of future discounting and how it influences delinquent behavior. I primarily use the phrase “anticipated early death” (AED) throughout the dissertation, in part because my outcome measures are of violence that could result in an -

increased risk of early death. Furthermore, this terminology is common in studies of this concept published in criminology (i.e., Brezina et al., 2009; Piquero, 2016; Tillyer, 2015), as well as in other fields.

Anticipated early death has many correlates that make it a point of interest for scholars in several disciplines. The methods and hypotheses in studies of AED vary by discipline and the researcher's purpose. For example, psychological studies of AED often focus on its effects in terms of coping mechanisms. In the medical literature, scholars examine the relationships between AED and precocious sexual behavior or HIV status. AED has also been linked to risk-taking behaviors and offending, and researchers have studied delinquency as an effect of AED in criminology, psychology, evolutionary biology, and health disciplines. AED is interwoven with many other variables of interest in criminology, including victimization, depression, and substance abuse (Bolland, Lian, & Formichella, 2005; Borowsky, Ireland, & Resnick, 2009; Brezina et al., 2009; DuRant, Cadenhead, Pendergrast, Slavens, & Linder, 1994). As such, AED can be used as a marker for these other issues (Borowsky et al., 2009), covering a wide breadth and making it a valuable measure for people who study delinquency. Despite the consistent finding that AED leads to risky behaviors including crime and delinquency, however, AED is underutilized as an independent variable and is rarely operationalized in criminology. This lack of attention from criminologists is unfortunate given the otherwise vast attention devoted to the etiology and outcomes of delinquency.

In this dissertation, I examine the correlates of anticipated early death (AED) as well as its impacts on violence and gang activity throughout adolescence. Chapter 2 begins with a discussion of life history theory, the dissertation's guiding framework. I follow this with an assessment of why and how AED occurs, reviewing the literature on fatalism as it relates to

crime and delinquency. Two specific and problematic kinds of risk-taking behaviors – violence - and gang activity – receive special attention as the outcomes of interest in this dissertation. The chapter concludes with an introduction to the current study, its objectives, and an overview of the theoretical model tested in the dissertation. Chapter 3 contains the methods section, detailing the datasets, samples, variables, and analytical procedures employed in the dissertation. Four results chapters follow. In Chapter 4, I use factor analysis to create novel measures of AED in two longitudinal datasets. Chapters 5 and 6 present the results of structural equation models and multivariate regressions exploring the relationships between AED and violence and gang activity. Chapter 7 presents the results of autoregressive cross-lagged panel models to investigate causality in the AED/risky behavior relationship. The dissertation closes with a discussion of the findings, implications for research and practice, limitations of the current study, and recommendations for future research.

CHAPTER 2

Theoretical Framework and Literature Review

The concept of fatalism is basic, intuitive, and multidisciplinary, providing policy implications and avenues of further research for scholars of several criminological and psychological theories, e.g., rational choice, deterrence, learned helplessness, and life history theories. The common thread underlying all of these theoretical concepts is the extent to which individuals envision a long life under their control, facilitating both willingness and ability to pursue conventional activities with delayed and long-term benefits, such as education, employment, and marriage. In this dissertation, life history theory, drawn from the field of evolutionary biology by way of developmental psychology, provides a guiding theoretical framework.

Life History Theory and Future Discounting

In the study of anticipated early death in disciplines such as psychology and health, scholars often ground their research in life history theory (see, e.g., Caldwell, Wiebe, & Cleveland, 2006; Ellis et al., 2012; Simpson, Griskevicius, Kuo, Sung, & Collins, 2012). Life history theory hypothesizes that individuals accelerate their life choices in response to “extrinsic morbidity-mortality,” or “external sources of disability and death that are relatively insensitive to the adaptive decisions of the organism” (Ellis et al., 2012, p. 608). This bears similarities to the psychological concept of an external locus of control, whereby individuals perceive rewards or punishments as contingent upon chance or outside forces rather than resulting from one’s own actions (Rotter, 1966). Ellis and colleagues (2012) provide some examples of indicators of extrinsic morbidity-mortality, including exposure to violence, attending friends’ funerals in

adolescence, growing up in poverty, and rarely encountering elderly persons in the community. These factors often surround youth in urban areas, making it clear that reaching old age is not a guarantee in such an environment.

Life history theory posits that those who do not expect to live a long life cultivate fast life histories, meaning that immediate gratification is prioritized at the expense of long-term benefits. Because they have little hope for or certainty of the future, these individuals do not strive to achieve conventional goals like high school graduation, college enrollment, marriage, and steady employment. Instead, they are inclined to engage in risky behaviors because, as they see it, they have little or nothing to lose. Characteristics of an accelerated life history strategy include willingness to take risks, short-term planning, earlier sexual activity and reproduction, a greater number of sexual partners, casual sexual relationships, and lower investment in offspring (Ellis et al., 2012, p. 608).¹ Within the evolutionary biology framework, the employment of a fast life history strategy and the refusal to delay gratification are evolutionary tactics designed to optimize one's chances of reproduction. Accordingly, males who expect to die young reproduce often and with numerous mates in order to improve the chances that their genetic material will be passed on. Females who anticipate an early death are also more likely to reproduce (Caldwell et al., 2006), although less often than males given females' biological restrictions in that regard.

In short, at the core of life history theory is the concept that without expectation of a long, stable future, delaying immediate gratification in exchange for future rewards makes no sense (Caldwell et al., 2006). In other words, AED is an evolutionary response to an unpredictable, unstable environment in which longevity is not promised. Examination of AED from an

¹ In contrast, a slow life history strategy is characterized by avoidance of risks, long-term planning, later sexual activity and reproduction, fewer sexual partners, committed sexual relationships, and greater investment in offspring (Ellis et al., 2012, p. 608).

evolutionary model requires understanding that risky behavior in adolescence is not necessarily - maladaptive, as scholars have assumed when studying the issue from a psychopathology viewpoint (Ellis et al., 2012; Frankenhuis, Panchanathan, & Nettle, 2016; Simpson et al., 2012). Ellis and colleagues make the point that working from a psychopathology model “has led the field to largely neglect a critically important question: What is in it for the adolescent?” (2012, p. 600). As I discuss later in this chapter, some of the benefits of risky behaviors characteristic of a fast life history strategy for youth in dangerous urban environments include an impressive reputation and respect from one’s peers as well as psychological mastery of fear. These rewards serve as physical and psychological survival techniques of sorts, as well as means to facilitate reproduction in an evolutionary framework.

There exists further biological evidence to support this theory. Neurological research shows that the connections in the prefrontal cortex, the part of the brain responsible for regulating inhibition, do not fully develop until adulthood (Casey & Caudle, 2013; Figueredo et al., 2006; Giedd et al., 1999). Neuropsychologists posit that adolescent risk-taking results from tension between regions of the brain that process rewards (developed by adolescence) and regions of the brain that process control (not fully developed until adulthood) (Blakemore & Robbins, 2012; Casey & Caudle, 2013). However, adolescent behavior is not simply explained as “all gas, no brakes” (Casey & Caudle, 2013). In “cool” (i.e., non-emotional, low-arousal) situations, adolescents actually think and behave just as rationally as adults (Blakemore & Robbins, 2012; Casey & Caudle, 2013). It is only under “hot” circumstances – in emotional, high-arousal situations – that adolescents’ regulation of control diminishes. These findings are complementary to the suppositions of life history theory.

The literature abounds with examples of “hot” circumstances in which adolescents, typically males, are more likely than usual to take risks. For example, young men are more likely to engage in risky behavior and aggression when they face a challenge to their masculinity or status or when they have an opportunity to demonstrate nerve or save face before an audience (Anderson, 1999; Blakemore & Robbins, 2012; Casey & Caudle, 2013; Courtwright, 1998; Ellis et al., 2012; Gallup, O’Brien, & Wilson, 2011; Griskevicius et al., 2009; Hughes & Short Jr., 2005; Wilson & Daly, 1985). This is especially true when the audience is primarily male. Griskevicius and colleagues hypothesize that men “might try to control their public aggression displays in front of prospective mates, because violent tendencies may decrease a man’s attractiveness” (2009, p. 991). Risky behavior undertaken by young males, especially before an audience of one’s peers, serves primarily to establish status or dominance among one’s sexual competitors (i.e., other young men).

Adolescent males who accelerate their life histories typically engage in risky behaviors, sometimes including violent offending. This violence is driven in part by competition with other young men in pursuit of mating opportunities. Wilson and Daly (1985) explored the tendency for men to murder each other over seemingly trivial conflicts such as disputes over negligible amounts of money. They argue that in these cases, the men are not just fighting over a few dollars; they are fighting to save face and gain or maintain status in the community and particularly before their peers. Griskevicius and colleagues (2009) termed this phenomenon “aggress to impress,” and Alexander (1979, p. 241) described the male life strategy as “higher-risk, higher-stakes,” compared to that of females.

As many qualitative studies of crime and delinquency demonstrate, offenders are aware that they use the “aggress to impress” strategy. Given the numerous potential motivations and

results (including procreation), though, life history theory makes no assumptions about whether - actions follow a rational weighing of the potential costs and benefits of taking the risk (Wiebe, 2012). In one study, Wilson and Daly (1997) observed that one's expected lifespan need not be consciously observed in order to influence behavior. However, in another paper, they pointed out that of the murderers in their sample who ultimately received a criminal conviction, the majority received a charge no harsher than manslaughter, punishable by three to five years in prison with eligibility for parole after 18 months (Wilson & Daly, 1985). This cost (that is, a lenient short-term sentence) may not outweigh the benefits of saving face and demonstrating masculinity, which has the potential to earn lifelong respect in the community. Even the ultimate risk – death – may not deter violence. For some youths in dangerous communities, the best way to gain a reputation as a tough man deserving of respect is by displaying a lack of fear of death. Anderson observed that “among the hard-core street-oriented, the clear risk of violent death may be preferable to being dissed” (1999, p. 92). Backing away from a conflict when one's status hangs in the balance may not be worth the potential lifetime of disrespect that follows. In these situations, the engaged parties conclude (perhaps unconsciously or without formal consideration) that they have little to lose but much to gain.

There are many reasons adolescents may reach the conclusion that they have little to lose, resulting in AED and discounting of the future. In the next section, I review the AED literature through the life history theory lens, describing specific factors that contribute to fatalistic attitudes.

Review of the Literature

Anticipated early death.

The literature on AED generally focuses on adolescents and ignores adults, who estimate their likelihood of death more accurately than adolescents (Hurd & McGarry, 1995). A common stereotype maintains that adolescents feel invulnerable (Borowsky et al., 2009), thinking “it can’t happen to me.” The research suggests the opposite, however – adolescents actually overestimate their chances of dying early. Jamieson and Romer (2008) found that about 1 in 15 young people (about 7%) expected to die at an early age, and Fischhoff and colleagues (2000) reported that the National Longitudinal Survey of Youth 1997 (NLSY97) respondents thought they had a 20% chance of dying by age 20, on average. These estimates are wildly inaccurate – in 2010, the actual probability of dying by age 20 was just 1.09% (Arias, 2014); the probability of death at younger ages was even lower, as probability of death increases with age (Bell & Miller, 2005). These numbers illustrate the vast gulf between the reality of an early death and adolescents’ perceived chances of death.

Though inaccurate, these perceptions of an inflated probability of dying young are not entirely unfounded. While chances of death for American youth are minimal, generally speaking, some people do have a greater likelihood of dying young. Specifically, young men of color face a greater risk of death than their female and white peers. The mortality rate for males aged 15 to 24 in 2010 was 97.6 per 100,000, compared with 36.4 per 100,000 for females of the same age group (Murphy, Xu, & Kochanek, 2013). For the same age group, the mortality rate for non-Hispanic blacks was 98.3 per 100,000, while it was 66.4 per 100,000 for non-Hispanic whites. An examination of the intersection between race and gender is particularly revealing. The highest

mortality rate for groups aged 15 to 24 in 2010 was 150.8 per 100,000 for black males; the rate for non-Hispanic white females was drastically lower, at 38.4 per 100,000.

These differences are even more pronounced when comparing mortality rates by cause of death. For example, homicide was the leading cause of death for black males aged 15 to 24 in 2010 (Centers for Disease Control and Prevention, 2012). Among all black males in this age group who died in 2010, half (49.7%) were murdered. In comparison, only 8.9% of similarly-aged white males who died in 2010 were victims of homicide (the third leading cause of death for whites, behind accidents and suicide). These statistics make it clear that not everybody has the same chance of death at any given time – black males are more likely to die, particularly as a result of homicide, than others. However, race and sex are not the only factors that influence one’s odds of suffering an early death.

Mortality rates among youthful offenders, regardless of race, are disproportionately high. Teplin, McClelland, Abram, and Mileusnic (2005) found that youth in juvenile detention facilities had mortality rates more than four times higher than the general youth population. Of the individuals who died in their study, 90% were victims of homicide, most dead as a result of gunshot wounds. The remaining 10% of deaths were due to legal intervention, suicide, or accidents; all of the deaths were due to external causes. Thus, anticipation of an early death for youth in urban communities, and especially for young men of color who engage in crime, has some grounding in reality. Regardless, the chances of dying early are low, even for incarcerated youth – only 3.55% of the entire sample (65 of 1,829) in Teplin and colleagues’ (2005) study died between ages 15 and 24. Even among this high-risk sample, the chances of death were much lower than adolescents in nationally representative samples believe they are (Fischhoff et al., 2000; Jamieson & Romer, 2008). -

Common sense suggests that fear of an early death might encourage youths to behave with caution in the interest of self-preservation. Conversely, research indicates that expectation of a premature demise makes adolescents more likely to engage in risky behaviors, adopting a “live fast, die young” mentality. “Tomorrow ain’t promised to you” (Anderson, 1999, p. 136), so one must make the most of the time available. Life in a dangerous, unpredictable environment such as the violent inner-city “war zones” described by Garbarino and colleagues (1991) contributes to this mindset. Such a setting can produce an external locus of control, where the youth believes he or she is powerless to affect his or her future (Rotter, 1966; Twenge, Zhang, & Im, 2004). As many participants in qualitative studies such as Anderson’s *Code of the Street* (1999) have observed, there is no incentive to live cautiously when your own behaviors appear to have no bearing on your future. Instead, an external locus of control and a dangerous or unpredictable environment may encourage risk-taking behaviors such as delinquency. However, it is also possible that the reverse is true – that is, engaging in risky behaviors such as violent offending may cause one to expect an early death as a result of these actions.

Causal ordering.

The most daunting task facing AED researchers is the establishment of temporal order – determining whether development of fatalistic attitudes precedes risky behavior, or vice versa. When Borowsky and colleagues (2009) attempted to solve this problem using data from the National Longitudinal Study of Adolescent Health (Add Health), the researchers found that both possibilities occurred; the variables seemed to cause each other. The difficulty in establishing temporal order regarding AED lies in the possibility that it is ingrained in an individual beginning in early childhood, particularly when the environment is a contributor (as it frequently

seems to be, at least in urban areas). Thus, it is not easy to identify a specific moment when one began to expect an untimely death.

Although the causal ordering has not been definitively established, Simpson and colleagues (2012) found that unpredictability in early life (ages 5 and below) predicted risky behaviors at age 23 better than did unpredictability from ages 6 to 16. This suggests that AED (as approximated by environmental unpredictability) does precede risk-taking. Also, if fatalism is instilled in early childhood, it is safe to assume that it precedes participation in risk-taking behaviors like delinquency, which begin later in life. However, even if this assumption were true, identification of AED's starting point would still prove useful for determining the optimal time to apply interventions to reduce or prevent AED.

Establishing causal order may pose a challenge, but it is not an insurmountable task. Although Simpson and colleagues (2012) did not look specifically at AED, their approach could be useful in the study of fatalism. Because determination of causal order with AED is difficult to accomplish, examination of likely predictors of fatalism from birth through childhood and adolescence may allow the researcher to better establish temporal order of fatalism and risk-taking behaviors.

The approach used by Simpson and colleagues (2012) requires access to longitudinal data, which could help determine whether AED or risky behavior comes first. However, AED may be a subtle, subconscious concept rooted in early childhood. Determination of causal ordering might therefore be impossible with data that begin during adolescence or later – data including characteristics from early childhood could be the only way to untangle the temporal ordering of AED and risk-taking behavior, and even with such data it may still be difficult to pinpoint when AED begins. Despite this challenge in the study of AED, it remains an important

concept due to the relationships between AED and risky behavior and numerous other causes and - effects of delinquency.

Correlates of AED.

Researchers have found many factors that contribute to fatalistic attitudes, including a number of demographic characteristics such as sex, age, and socioeconomic status.

Males expect to die at younger ages than females (Piquero, 2016). This may be due to the fact that they are actually more likely to die young, and to die at younger ages, than females. Another potential cause for this disparity is the tendency for males to engage in risky behavior. To gain an edge in the competition for reproductive success, adolescent males take risks, particularly in social settings, because this confers status and makes them more intrasexually competitive (Ellis et al., 2012; Gallup et al., 2011; Griskevicius et al., 2009; Sylwester & Pawłowski, 2011; Wilson & Daly, 1985).

Other demographic factors have received less consistent substantiation in the AED literature. Tillyer (2015) found that older teens were more likely to expect to be killed by age 21; however, Bolland and colleagues (2005) found that age was negatively related to hopelessness.² Youth with unemployed parents are more likely to expect to die early (Duke, Skay, Pettingell, & Borowsky, 2009; DuRant et al., 1994). Along those same lines, Tillyer (2015) and Borowsky and colleagues (2009) found that adolescents whose families received public assistance were more likely to anticipate an early death; however, Caldwell, Wiebe, and Cleveland (2006) found that fatalism is not confined to the economically disadvantaged.

Regarding racial and ethnic differences, Borowsky and colleagues (2009) found in an ethnically heterogeneous study that black, Hispanic, and Native American youths were all

² Hopelessness is not synonymous with AED, but the measure of hopelessness used by Bolland et al. (2005) included an item measuring whether the respondent expected to live a long life.

significantly more likely than white adolescents to expect an early death.³ Disconcertingly, “for poor black youth, one-third believed that their risk for early death was high,” compared with 17% of white youths receiving public assistance (Borowsky et al., 2009, p. e84). In another study, African American adolescents whose head of household was employed experienced lower levels of hopelessness than those with an unemployed head of household (DuRant et al., 1994). As I discussed earlier in this chapter, the increased risk of death for people of color, particularly by external causes such as homicide, likely contributes to the findings that nonwhite individuals are more likely to expect an early death – they are actually more likely to die early. The political climate and recent media focus on deaths of people of color at the hands of law enforcement officers likely further contributes to AED among the nonwhite population, but any recent increase due to the “Black Lives Matter” movement isn’t yet captured in the literature (although such fears certainly predate the movement and its media attention).

Scholars have linked several psychological characteristics to AED as well. Youths with low self-esteem and poor perceptions of their own health are more likely to anticipate an early death (Duke, Borowsky, Pettingell, Skay, & McMorris, 2011; Duke et al., 2009; Swisher & Warner, 2013), as are those with decreased levels of connectedness to their families, schools, peers, and communities (Bolland et al., 2005; Caldwell et al., 2006; Duke et al., 2009). Similarly, poor academic performance, as measured by a respondent’s grade point average and whether he or she has repeated a grade level, is also linked to AED (Caldwell et al., 2006; Duke et al., 2009). These components of negative or stressful environments all contribute to “bad” developmental outcomes as defined by modern Western values, including poor health, substance abuse, and teenage pregnancy (Ellis et al., 2012).

³ However, in his sample of serious youthful offenders, Piquero (2016) found that Hispanic adolescents expect to die at younger ages than both black and white youths.

Disturbances and interruptions during childhood and adolescence also contribute to feelings of unpredictability and an external locus of control. Bolland and colleagues (2005) found that increased levels of disruption (including witnessing violence, traumatic stress, worry, and change in mother figure) were associated with hopelessness among urban African American adolescents. On a related note, researchers have found significant relationships between AED and variables that generally measure future orientation, such as suicide attempts, educational aspirations, depression, and feeling hopeful (Borowsky et al., 2009; Duke et al., 2009; Swisher & Warner, 2013; Tillyer, 2015). Sadly but predictably, Tillyer (2015) found that adolescents with a deceased parent were more likely to expect to be killed by age 21. The early death of one's parents, before their offspring reached 21, may be the starkest reminder of one's mortality.

As many qualitative urban researchers have found, fatalism is most commonly correlated with exposure to violence and victimization (Anderson, 1999; Bolland et al., 2005; Brezina et al., 2009; Decker & Van Winkle, 1996; Duke et al., 2009; DuRant et al., 1994; Hoffman, 2004; Kotlowitz, 1991; Silberman, 1978; Swisher & Warner, 2013). It is important to note that while most studies have similar findings about the relationships between AED and victimization and exposure to violence, Bolland and coauthors (2005) found that sexual and violent victimization were *not* associated with fatalism. The fact that there are conflicting findings about whether violent victimization – something that logically seems like it would be one of the strongest predictors of fatalism – is related to AED illustrates the complexity of the issue and the need for more research on the topic.

The stressful environment that contributes to AED often stretches beyond one's immediate surroundings. Most studies of anticipated early death operate at the individual level, but community characteristics may influence fatalism as well. In a study conducted at the

neighborhood level, Wilson and Daly (1997) concluded that low life expectancy in the - neighborhood resulted in residents discounting the future. Similarly, those who live in neighborhoods with physical and social disorder or high levels of disadvantage anticipate dying at young ages (Piquero, 2016; Swisher & Warner, 2013). Duke and colleagues (2009) found that several community characteristics, including parents' community involvement and feeling safe in and connected to one's neighborhood, were significantly correlated with AED. In a sample of socioeconomically homogeneous neighborhoods, Bolland and colleagues (2005) found that neighborhood consistently predicted hopelessness; they recommended further research to identify ecological characteristics that affect risky behavior.

Especially in combination, the factors listed in this section (e.g., unemployed or deceased parents, witnessing or experiencing violence, living in an area with low life expectancy) result in an unpredictable environment. Growing up in such a setting fosters an external locus of control and expectation of an early death (Hill, Ross, & Low, 1997). These beliefs, in turn, predict risk-taking behaviors in several arenas, such as safety, sexual behavior, and personal relationships (Hill et al., 1997). Individually, the stressors identified in the literature predict AED. In combination, due to the resulting unpredictability of the environment, the effect is amplified.

AED in quantitative criminology.

Of the publications discussed in this summary of AED research, only three studies (i.e., Brezina et al., 2009; Piquero, 2016; Tillyer, 2015) explicitly examined AED and were published in criminological journals. Below, I describe these studies and then discuss some of the gaps in the AED criminological literature.

In the mixed-methods study by Brezina and colleagues (2009), quantitative analysis of a nationally representative sample (Add Health) indicated that adolescents who perceived a greater

than 50% chance of being killed by age 21 or dying by age 35 were significantly more likely to engage in criminal behavior, including property crimes, graffiti, robbery, and assault. Qualitative interviews of young African American offenders in Atlanta supported the findings of the statistical analyses. The interviewed participants expressed no fear of death, instead accepting the possibility of an untimely death as a fact of life (Brezina et al., 2009). The qualitative interview data allowed the researchers to deepen their understanding of fatalism as they gathered knowledge about participants' personal experiences with violence and AED. Consistent with the findings of most psychological and qualitative criminology studies (Anderson, 1999; Bolland et al., 2005; Decker & Van Winkle, 1996; DuRant et al., 1994; Hoffman, 2004), the interviewees stated that they experienced AED as a result of victimization and regular exposure to violence. Additionally, some of the qualitative participants revealed that family and friends reinforced feelings of AED in order to either indoctrinate them into the violent subculture or in an attempt to scare them away from a life of delinquency (Brezina et al., 2009). The use of qualitative interviews, especially with a focus on AED and offending, provides a richer understanding of the relationship between the two. This research took a huge step, confirming a statistically significant link between AED and delinquency. Furthermore, the authors capitalized on their longitudinal data by measuring AED during the wave prior to the measurement of offending (although some subjects had likely already begun offending by that time).

Drawing on the findings of Brezina and colleagues, Piquero (2016) used quantitative techniques to determine the effects of AED on trajectories of offending. He found that those who expected to die at younger ages were more likely to fall into the "late desister," "persister," or "early desister" offending trajectories, compared to the "low" offending trajectory.⁴ To

⁴ The remaining trajectory category, "moderate," did not significantly differ from the "low" trajectory.

approximate the analysis by Brezina and colleagues (2009), Piquero also re-estimated his - analyses using a variable measuring whether subjects believed they would be dead by age 35. He observed similar patterns as before (i.e., late desisters, persisters, and early desisters expected to die at earlier ages than low offenders did). Additionally, he found that people who expected to die by 35 reported greater perceived benefits and lower perceived costs of offending. These individuals also had less impulse control than those who expected to live beyond 35. Unfortunately, Piquero's study did not establish the causal order of AED and offending; in his sample of serious adolescent offenders, measurement of AED followed offending.

Most recently, Tillyer (2015) used the Add Health data to study the influences of victimization, witnessing violence, and engaging in delinquency on perceived risk of being killed by age 21. This study was the first to establish a statistical link between violent victimization and AED, providing quantitative support for a relationship that qualitative researchers have observed repeatedly. However, once independent variables measuring delinquency were added to Tillyer's model, victimization was rendered insignificant. To explain this development, Tillyer speculated that "perhaps surviving violent victimization leads to feelings of invincibility, anger, and/or recklessness, thus emboldening individuals to engage in delinquency, which in turn influences perceptions of risk" (2015, p. 538). Unfortunately, all of the key variables in Tillyer's study were measured at the same point in time, making it impossible for her to test the hypothesis that victimization results in offending, which increases one's perceived risk of death.

Most relevant to this dissertation, Tillyer (2015) found significant relationships between AED and violent offending and gang membership (again, the variables were measured at the same time). However, the study found no significant links between AED and witnessing violence or engaging in nonviolent crime (specifically, property crime, drug sales, and drug use). In

contrast, Brezina and colleagues (2009), also using the Add Health data, did find a link between AED and property crime; they did not consider drug sales or use.

Another key difference between the studies is the operationalization of AED. The Add Health data contain two variables measuring AED: “What are the chances you will live to age 35?” and “What are the chances you will be killed by age 21?” Brezina and colleagues (2009) utilized both of these variables separately, finding similar results for the two items (i.e., those who reported a greater than 50% chance of being killed by age 21 were significantly more likely to engage in offending, as were those who reported a less than 50% chance of living to age 35). Tillyer (2015) only considered the variable measuring perceived chances of being killed by age 21. Her study was the first to specifically consider this item on its own; other studies on AED using Add Health data have either used both AED measures or the “live to age 35” measure alone. The varying operationalizations of AED in the studies by Tillyer and Brezina and colleagues might account for their differing findings regarding AED’s relationship to nonviolent offending. The measure used in Tillyer’s study (i.e., “What are the chances you will be killed by age 21?”) connotes a violent death, resulting from an assault or an accident (although Tillyer focuses more on a connotation of death as a result of homicide rather than an accident). The question’s emphasis on violence may explain Tillyer’s findings that AED is linked to violent offending but not nonviolent crime. That is, perhaps violent youth expect to die violently while teens who commit other crimes see no link between their behavior and violence.

The three studies discussed here provide an excellent introduction of AED into quantitative criminology. However, despite these contributions, a disconnect remains between the criminological literature and disciplines that have a longer history of AED research (e.g., psychology and health disciplines). For example, Piquero (2016) found that age, sex, race, and

community characteristics are determinants of AED. As described earlier, the literature supports use of these variables as predictors of AED. However, Piquero did not consider important individual and family factors that psychological and health studies have found to contribute to AED. Brezina and colleagues (2009) used AED solely as an independent variable and therefore did not attempt to identify determinants of AED,⁵ although they acknowledge the importance of such research to inform intervention programs and reduce crime. The exclusion of key AED risk factors identified in other disciplines reveals the gap between criminology and AED research in other fields. The recent study published by Tillyer greatly improves on these shortcomings. In addition to sex, race, and neighborhood variables (none of which predicted AED), Tillyer (2015) included measures of other known or potential correlates of AED, i.e., welfare receipt, depression, having a deceased parent, and impulsivity. With the exception of impulsivity, these variables all predicted AED in Tillyer's (2015) multivariate regressions. The further addition of AED correlates to criminological research on AED would allow researchers of crime and delinquency to gain a better understanding of the relationships between AED and other commonly studied concepts such as self-esteem and neighborhood disorganization.

As in most AED research, the three quantitative criminological AED studies are limited in that they do not definitively establish causal ordering of AED and risky behaviors. Brezina and colleagues lagged their AED independent variable one wave, but many subjects were probably already engaged in delinquency given that Add Health's Wave I respondents were drawn from grades 7 through 12. Likewise, Tillyer drew most of the variables in her study from

⁵ They did, however, control for several variables that other scholars have found to be related to AED (i.e., age, sex, ethnicity, family income, parents' receipt of welfare, abuse by caregivers).

Wave II of Add Health.⁶ Piquero's sample consisted of serious adolescent offenders, so AED was necessarily measured after criminal activity occurred. Despite this limitation, these studies have demonstrated significant linkages between AED and different types of crime as well as trajectories of offending. However, the causal direction of these relationships remains unknown.

Having reviewed the literature of AED (my independent variable), I next review the literature on gangs and violence (my dependent variables), as it relates to AED.

Gangs and violence.

Urban youth often find themselves surrounded by violence (Garbarino et al., 1991). This dangerous and unpredictable setting contributes to an external locus of control, and youth who grow up and live in this environment see plenty of reasons to expect an early death (Ellis et al., 2012). For some young people who grow up with little hope for the future, AED manifests as risk-taking behaviors, including delinquency. Due to the sparse literature on AED, the specifics of the AED-delinquency relationship (e.g., temporal ordering, effects on frequency or specific types of offending) remain unclear.

Quantitative criminological research has not exploited the potential link between AED and gangs or violence, the outcomes of interest in this dissertation. Tillyer (2015) and Brezina and colleagues (2009) found a relationship between AED and violent offending, but this relationship was not explored in depth using quantitative analysis. However, qualitative research, including the interviews conducted by Brezina and colleagues, suggests that AED is likely predictive of gang activity and violence. For those who do not expect a lengthy future, the costs of criminal behavior are minimal. Brezina and colleagues (2009, p. 1118) suggest that AED

⁶ In predicting AED at Wave II, Tillyer (2015) did include a control measure for perceived risk of being killed by age 21 at Wave I. AED at Wave I was the strongest predictor of AED at Wave II, more than quadrupling the odds of expecting to be killed by 21.

promotes attraction to risky behavior because, as one of their subjects said, “If I see something I want I take it right then because that might be your only chance in this world to get some.” In other words, for a person who believes he could die at any moment, what is to be lost by taking a risk that might yield a sizeable payoff?

Although the topic of fatalism arises in many qualitative studies of gangs, crime, and urban areas (see Anderson, 1999; Decker & Van Winkle, 1996; Hoffman, 2004; Kotlowitz, 1991; Miller, 2001; Venkatesh, 2008), research focusing directly on the relationship between AED and gang membership is lacking. Ample evidence suggests that anticipation of an early death could contribute to one’s decision to join a gang – for example, one participant in Hoffman’s study stated that hopelessness drove him to join a gang for protection and solace (2004, p. 92). Additionally, one of Miller’s focal concerns of lower class culture resulting in gang membership is fate, defined as the feeling among “many lower class individuals ... that their lives are subject to a set of forces over which they have relatively little control” (1958, p. 11). Despite anecdotal research indicating that a fatalistic attitude contributes to one’s decision to engage in or desist from gang involvement, criminologists have yet to explore this statistically.⁷

There are several reasons AED might predict violence and gang involvement. First, in urban communities with limited resources, “respect on the street may be viewed as a form of social capital that is very valuable” (Anderson, 1999, p. 66). For young males in particular, violence enables one to demonstrate masculinity, establish a reputation, and earn the respect of peers (Anderson, 1999; Fagan & Wilkinson, 1998; Griskevicius et al., 2009; Silberman, 1978; Wilson & Daly, 1985). According to Anderson, young urban males must establish their manhood

⁷ The exception to this statement is the 2015 study by Tillyer, who found that gang membership predicted perceived risk of being killed by age 21. However, the cross-sectional nature of the study precludes determination of causal ordering.

in order to gain respect in the community: “Central to the issue of manhood is the widespread - belief that one of the most effective ways of gaining respect is to manifest nerve.... True nerve expresses a lack of fear of death” (1999, p. 92). One way to demonstrate nerve and earn respect in an urban area may be to join a gang (Maxson & Whitlock, 2002). The use of violence and/or gang membership as a demonstration of bravery allows young men in urban communities to establish manhood and gain admiration.

Not only does use of violence serve the purpose of facilitating attainment of respect, but it can also benefit the perpetrator psychologically. As Anderson stated, “Conveying the attitude of being able to take somebody else’s life if the situation demands it gives one a real sense of power on the streets” (1999, p. 92). Similarly, Lorion and Saltzman (1993) and Tolleson (1997) observed that those who anticipate an early death may engage in violence in order to gain a sense of control in an unpredictable environment. Silberman (1978, p. 112) remarked that “action, in whatever form, provides a chance to demonstrate their ability to face a challenge and overcome it, and hence to offset the impotence they normally feel.” Tolleson’s (1997) interviews with four highly violent black inner-city gang members revealed that childhood exposure to death and violence in one’s community resulted in some gang members harnessing violence to maintain a sense of invincibility and overcome the ever-present threat of death. Tolleson (1997) describes this process using vivid language:

The perpetration of violence by some Black urban gang members constitutes a powerful and effective psychological adaptation to the trauma imposed by the unremitting presence of violent morbidity among young Black males in the inner-city. Specifically, the gang member’s enactment of violence may reflect his active attempts to re-render his inner

life, to supplant fear, helplessness, and passivity with omnipotence and mastery in the face of chronic and keenly felt endangerment. (p. 417)

For inner-city boys, Tolleson goes so far as to call perpetration of violence “one of their most precious psychological commodities” (1997, p. 429). People cope with stressful experiences in the best way they can. Unfortunately, aggression may be the only coping mechanism possessed by people who grow up in violent environments.

This use of violence as a coping skill is best exemplified in Decker’s study on normative gang violence. Decker (1996) asked gang members how they thought gangs could be eliminated. Instead of the expected responses such as education and job opportunities to divert people from gang activity and address root causes, the researchers were shocked that the modal response was violence. One-quarter of their subjects believed the only way to eliminate gangs would be to kill all gang members. This poignant example illustrates gang members’ submersion in a culture of violence.

In gang research, violence is a recurring theme. Many gang members report having joined the gang for protection from violence (Peterson, Taylor, & Esbensen, 2004; Thornberry, Krohn, Lizotte, Smith, & Tobin, 2003), but victimization increases when one is in a gang (Curry, Decker, & Egley, 2002; Peterson et al., 2004). Violence is also key in gang desistance – almost all gang members eventually exit the group, most within one year (Thornberry et al., 2003), and many report leaving due to violence (Decker & Lauritsen, 2002; Decker & Van Winkle, 1996; Hoffman, 2004). For example, 14 of the 24 former gang members interviewed by Decker and Van Winkle said they had left the gang because a friend had been killed; three others left the gang because they were shot, and one person exited the gang after being stabbed (1996, p. 269).

For some people, a violent lifestyle does ultimately encourage desistance. In a qualitative study of young people who had been victims of violence (many of whom were paralyzed due to spinal cord injuries resulting from gunshots), Hoffman (2004) found that many of her participants “accepted the likelihood of death as normal” (p. 62), and several former gang members reported that suffering paralysis or losing a loved one to violence catalyzed desistance from the gang. However, many of the participants in her study had sustained multiple gunshots and lost many friends and family members to violence over several years’ time – one personal experience with extreme violence was not enough to persuade these gang members to make a change. Hoffman’s findings suggest that a lifestyle of extreme violence is not sustainable. Eventually, the engaged parties either die or are so badly injured that they can no longer participate.

Outsiders may contemplate situations such as those described by Hoffman and conclude that the logical response is to extract oneself from the violent lifestyle. Although this does happen, it is likely difficult for adolescents in dangerous urban settings for several reasons. First, if violence is the primary conflict resolution technique young people have observed at work in the community, they are unlikely to develop nonviolent resolution methods on their own. Additionally, violence is an escalating process by its nature, creating a contagious feedback cycle (Loftin, 1986). That is, one violent offense begets retaliation from the victim, and the first person responds to the retaliatory event in kind. Finally, it is unreasonable to expect one to suddenly cut all ties to his or her community. This is especially impractical for people of limited financial means, and most people would be unwilling to cut ties with their social networks, even if they had the ability to do so. In a study of desistance from gangs, Pyrooz, Decker, and Webb (2014) found that gang desistance is a gradual process, depending on the extent of one’s continuing ties

to the former gang network. Even when people do have the capability and choose to leave the - life of violence behind, such a process typically occurs bit by bit, over an extended period of time.

AED research indicates that, when faced with unpredictable and dangerous environments, adolescents tend to take risks instead of playing it safe. While AED has received substantial attention in relation to risky health and sexual behaviors, its connection to delinquency remains understudied. This dissertation adds to the literature on AED and delinquency, particularly with regard to violence and gang activity.

Self-control.

A psychological concept closely tied to both future discounting and risky behavior is self-control. Gottfredson and Hirschi (1990) proposed that low self-control results primarily from ineffective child-rearing, and it stabilizes early in life. In the quarter century that has passed since Gottfredson and Hirschi published their theory, a wealth of research has tested the relationship between self-control and crime, typically finding a strong association. In a meta-analysis of 21 empirical studies, Pratt and Cullen (2000) found that low self-control consistently predicted criminal behavior with an effect size exceeding .20, even when studies controlled for opportunity and other theories of crime. Additionally, self-control's effect size remained large regardless of the ways in which studies operationalized self-control. Given the strength of the relationship between self-control and crime, Pratt and Cullen go so far as to conclude that "these considerations suggest that future research that omits self-control from its empirical analyses risks being misspecified" (2000, p. 952).

Life history theory, in its focus on evolutionary biology, does not incorporate self-control into the relationships between short time horizon, risky behavior, and reproduction. However,

self-control is closely related to both risky behavior and future discounting. Gottfredson and Hirschi listed six traits that describe people who lack self-control: impulsive, insensitive, physical, risk-taking, short-sighted, and nonverbal (1990, p. 90). Their definition of self-control includes both risk-taking and short-sightedness, two concepts I explore in the dissertation. Critics of the general theory of crime claim that it is tautological because Gottfredson and Hirschi describe low self-control as the propensity to commit crime, essentially proposing that propensity to commit crime causes crime (Akers, 1991; Geis, 2000). Akers (1991) recommends measurement of independent indicators of self-control to avoid tautology. Other researchers have studied Gottfredson and Hirschi's six subsets of self-control independently; they stand on their own as separate concepts (LaGrange & Silverman, 1999). Specifically, studies have found that future discounting and impulsivity are different constructs that may be unrelated (Bickel, Yi, Kowal, & Gatchalian, 2008; Burt & Simons, 2013; Copping, Campbell, & Muncer, 2014; Hill et al., 1997; Mishra & Lalumière, 2011; Wilson & Daly, 2006). There are even some conflicting findings about whether AED and impulsivity are related – Tillyer (2015) found that impulsivity did not predict AED, but Piquero (2016) found that it did. In the context of this study, inclusion of risk-taking or present orientation in the definition of self-control is inappropriate. Instead, more suitable measures of self-control (described in detail in Chapter 3) will emphasize temper and impulsivity.

Omission of self-control from this dissertation, given its strong link to both future discounting and risky behavior, would be problematic. Many studies show links between low self-control and violence and gang activity (e.g., Deschenes & Esbensen, 1999; Esbensen et al., 2009;⁸ T. I. Hope & Damphousse, 2002; Kissner & Pyrooz, 2009). However, most of these

⁸ Esbensen et al. (2009) found that self-control predicted violence only, not gang membership.

studies include measures of both impulsivity and risk-seeking in their operationalizations of self-control. One study that separately evaluated the effects of some of Gottfredson and Hirschi's subsets found that only carelessness (what Gottfredson and Hirschi called insensitivity) and present orientation (short-sightedness) predicted violent offending – impulsivity, risk-seeking, and temper did not (LaGrange & Silverman, 1999). These broad and sometimes dissimilar findings regarding the components of self-control and their effects on offending highlight the complexity of self-control measurement.

Another reason for inclusion of self-control in life history research is the relationship between self-control and sexual activity. Unsurprisingly, youths with low self-control are more likely to be sexually active and they also have a greater number of sexual partners (Hope & Chapple, 2004). Hope and Chapple (2004) found that self-control mediates the relationships between structural factors (i.e., poverty, sex, age, and race), parental behaviors, and adolescent sexual behavior. It is likely that self-control affects delinquency and sexual behavior given the associations scholars have found between AED and structural factors, family factors, and risk-taking behaviors, and self-control and risk-taking behaviors, AED, and sexual behaviors.

Current Study

Although AED is a relevant concern in many other situations (e.g., among terminally ill individuals, soldiers, or civilians living in war-torn areas) this dissertation focuses on AED in American youth. Researchers in several disciplines (criminology, psychology, evolutionary biology, health) have linked AED to delinquent behavior. The influence of AED on risk-taking behavior makes its study particularly relevant to the social sciences and criminology in particular. Knowledge of adolescent risk-taking behavior is a key component of the study of crime for obvious reasons – criminality increases during adolescence, and crime is a risk-taking

behavior. Research suggests that AED leads to crime – free from fear of death and danger, adolescents who expect to die young engage in delinquency because fear does not deter them (Anderson, 1999; Brezina et al., 2009; Tolleson, 1997). For years, qualitative sociological and psychological studies have suggested that many delinquent adolescents possess fatalistic attitudes, and that such beliefs are significantly related to outcomes such as drug use and offending (Anderson, 1999; Hoffman, 2004; Silberman, 1978; Tolleson, 1997). In spite of this, AED, and its relationship with crime, has received little consideration in the field of criminology.

The goal of the dissertation is to determine the effects of AED on gang activity and violent delinquency, two specific and especially problematic risk-taking behaviors. More broadly, this study aims to quantify AED so researchers can apply this measure to existing and future social science datasets. To this end, I examine the ways in which researchers in other disciplines have studied AED. The knowledge gleaned from this examination of the literature then informs the measurement of AED in the dissertation (that is, I use variables that predict AED in other studies to create a proxy measure of future discounting). The specific objectives of the dissertation, which are described in greater detail in Chapter 3, are as follows:

Objective 1: Operationalize a quantifiable measure of AED.

Objective 2: Examine the impacts of AED on individual violence and gang activity (including gang membership, duration, and stability), two extremely risky behaviors.

Objective 3: Determine the causal ordering of AED and delinquent risk-taking behaviors (i.e., violence and gang activity).

Due to the relative novelty of AED as a concept of study in the behavioral sciences, Caldwell and colleagues (2006) issued a call for more research on AED to create valid and reliable measures, explore the etiology of AED, and investigate various outcomes such as

depression, early childbirth, and delinquency. Piquero (2016) also called for additional measures of AED, as well as more quantitative studies of AED, use of longitudinal data in exploring AED, and examination of AED in samples of offenders. To address these gaps in the literature I use two longitudinal datasets to operationalize AED and then take advantage of the sample of at-risk individuals in the Rochester Youth Development Study (RYDS) to examine the effects of AED on criminality over time. Previous quantitative studies on AED in criminology (i.e., Brezina et al., 2009; Piquero, 2016; Tillyer, 2015) have explored its effect on offending in general. This dissertation focuses more specifically on violence and gang activity to explore the relationship between AED and these especially risky behaviors.

In addition to addressing Piquero's (2016) and Caldwell and colleagues' (2006) calls for additional measures of AED, study of AED in offenders, and quantitative longitudinal study of AED, I also confront the biggest problem in this arena – the establishment of causal ordering of AED and risk-taking behavior. A key benefit of the RYDS data that I employ in the dissertation is the large number of waves of data, collected from a sample of at-risk youth at six-month intervals throughout the teen years. The use of many waves of data, especially collected so close in time, allows for a better understanding of how AED and risky behaviors change and influence each other over time.

Theoretical Model

Chapter 2 has thus far described the basic tenets of life history theory and argued that life history theory provides the most appropriate framework for the current study. A combination of negative and stressful factors contributes to a shortened life expectancy, which drives adolescents and young adults to achieve their biological imperative, reproduction. Amongst young males in particular, engagement in risky behaviors such as acts of delinquency increases -

the chance of reproduction by establishing status and attracting a mate (or mates). For the remainder of the chapter, I describe the theoretical model and hypotheses I test in the dissertation.

Figure 2.1 illustrates the relationships explored in the dissertation. The first three paths (A, B, and C) illustrate the key relationships of interest. The other three paths (D, E, and F) represent those required in this context by life history theory. The most basic and direct hypothesis is that future discounting at time t will predict risk-taking behaviors at the subsequent observation period $t+1$ (path C). Specifically, I expect that youths who discount the future are more likely to engage in violence, to join a gang, and to stay in the gang for a longer and more stable period. According to life history theory, risk-taking behavior provides a way to facilitate procreation (the ultimate outcome of interest in evolutionary biology) for those who discount the future. In support of this hypothesis, numerous studies have found correlations between adolescent risk-taking behavior – aggression, in particular – and greater mating opportunities (Gallup et al., 2011; Palmer & Tilley, 1995; Sylwester & Pawłowski, 2011). This is particularly the case for males, who play a game with higher risks and higher rewards than females (Alexander, 1979; Daly & Wilson, 2005). Accordingly, I expect to find a significant relationship between AED and risky behaviors (path C) as well as an indirect effect of AED on reproductive behaviors through risk-taking behaviors (path C-F).

Females generally engage in far less delinquency than males, but they are not necessarily any less likely to discount the future. Males take risks in order to demonstrate their worth to potential mates, or to defeat the competition. Although females also compete for sexual partners, their aggression does not often take a physical form (Gallup et al., 2011; Griskevicius et al., 2009). Instead, teen girls are more likely to demonstrate superiority over their peers by teasing,

demeaning, and excluding them (Gallup et al., 2011; Pellegrini & Long, 2003) – behaviors that might be just as harmful as physical aggression in some ways, but behaviors that are not criminal or deadly. Regarding females, then, I hypothesize that those who anticipate an early death are more likely to experience a direct effect of AED on reproductive behavior (path E), without a mediating effect of delinquent risk-taking behaviors.⁹

Although Gottfredson and Hirschi included present orientation and thrill-seeking as subcomponents of self-control, research indicates that future discounting and risk-taking are separate constructs of risk propensity, independent of impulsivity (Bickel et al., 2008; Mishra & Lalumière, 2011). In fact, Mishra and Lalumière (2011) found that future discounting was not correlated with a “risky personality” measure. Thus, present orientation is not a personality characteristic in itself, but its effect on outcome behaviors could be mediated by “risky personality” traits such as impulsivity.

Low self-control is a strong predictor of delinquency for both males and females (LaGrange & Silverman, 1999). Hope and Chapple (2004) found that low self-control is also related to risky sexual behavior (i.e., having sex in adolescence, having a greater number of sexual partners, and having casual rather than committed relationships) for both sexes, although females generally have higher levels of self-control – and, consequently, lower levels of risky sexual behavior – than males. Given the previous findings on this subject – specifically, that impulsivity is related to AED (Piquero, 2016), delinquency (Pratt & Cullen, 2000), and sexual activity (Hope & Chapple, 2004) – I hypothesize that low self-control might mediate the

⁹ Reproductive behaviors such as becoming sexually active at an early age, engaging in sex with multiple partners, and becoming pregnant could be considered risk-taking behaviors in themselves in a modern social context that places more value on the path of a slow life history. In the evolutionary context, though, these behaviors are adaptive and they facilitate the goal of procreation.

relationships between AED, risk-taking behaviors, and sexual behaviors, with males engaging in - both delinquency and reproductive behaviors at higher rates and frequencies than females.

Clarke (2004) found that neuroticism mediates the relationship between locus of control and depression, speculating that a fatalist attitude stimulates worry and guilt, which fuel depression in turn. I suspect that the relationships explored in the dissertation follow a process similar to the one found by Clarke. I hypothesize that a higher level of AED corresponds to lower self-control, as operationalized with a focus on impulsivity and temper (path A). In turn, lower self-control increases the likelihood that an individual will engage in violence and gang activity (path B). The evidence other scholars have found for the associations between AED, low self-control, delinquency, and sexual behavior support the theoretical model.

In the latter portion of Figure 2.1, sexual behavior at time $t+2$ – operationalized as measures of pregnancy and number of sexual partners two observation periods after AED and one after risky behavior – assists me in evaluating the effectiveness of the AED measures using tests of predictive validity. Path D measures the influence of low self-control on the reproductive behaviors. I expect this path to be significant because Hope and Chapple (2004) found that low self-control predicted both sexual activity and number of partners in a sample of adolescents. Following the key tenet of life history theory, I also expect to find that higher levels of AED significantly predict pregnancy and number of partners (path E). This part of the model is important for validation of the latent measures of AED that I create in Chapter 4. Path F measures the effects of violence and gang activity on the reproductive variables. I expect a significant finding on this path as well, because adolescents engage in risky behaviors in order to attract a mate, according to life history theory. Moreover, research shows a significant

association between engaging in delinquency and sexual behavior (G. T. Harris, Rice, Hilton, Lalumière, & Quinsey, 2007).

In addition to the direct relationship between AED and reproductive behavior, I hypothesize that AED indirectly affects reproduction via violent behavior and low self-control. I also expect to find that AED influences both violence and reproductive behavior indirectly through low self-control. Consistent with life history theory, I anticipate that youths in negative and stressful environments have higher levels of AED. Particularly when young males with high AED find themselves in emotionally-charged, high-arousal situations, AED corresponds to lower self-control and, as a result, violent behavior and gang activity. This increases the likelihood of pregnancy and the number of sexual partners.

Although the final outcome of interest in Figure 2.1 appears to be sexual behavior, the true focus of the current study is on the relationship between AED and risk-taking behaviors, taking into account the possible mediating effects of self-control and moderating effects of sex. However, the reproductive variables are useful and important for substantiation of the newly-created AED proxy measures, as I describe in Chapters 3 and 4.

Though I find the relationships between future discounting, delinquency, and procreation fascinating, and I think these associations deserve more attention in the criminological literature, study of parenthood falls just outside the scope of the dissertation. I therefore discuss reproduction and parenting behaviors only in terms of life history theory and AED, stopping short of considering these concepts as outcomes or potential mediators for future offending.

Finally, Figure 2.2 illustrates the model to test causal ordering of AED and risky behavior. The key hypothesis of interest in the dissertation is that future discounting predicts risky behavior. However, it is likely that the reverse is also true; engaging in dangerous

behaviors probably results in anticipation of an early death as a consequence of these actions. As I discussed earlier, few studies have attempted to untangle the causal ordering of this relationship, but Borowsky and colleagues (2009) did find that AED and risky health behaviors were reciprocally related. To explore the direction of these relationships in the dissertation, I use eight waves of data from the Rochester Youth Development Study to evaluate the influences of AED on risky behavior at the next wave, and vice versa (i.e., the influences of risky behavior on AED at the next wave), throughout adolescence. The next chapter describes the datasets, samples, measures, and analytical plan in detail.

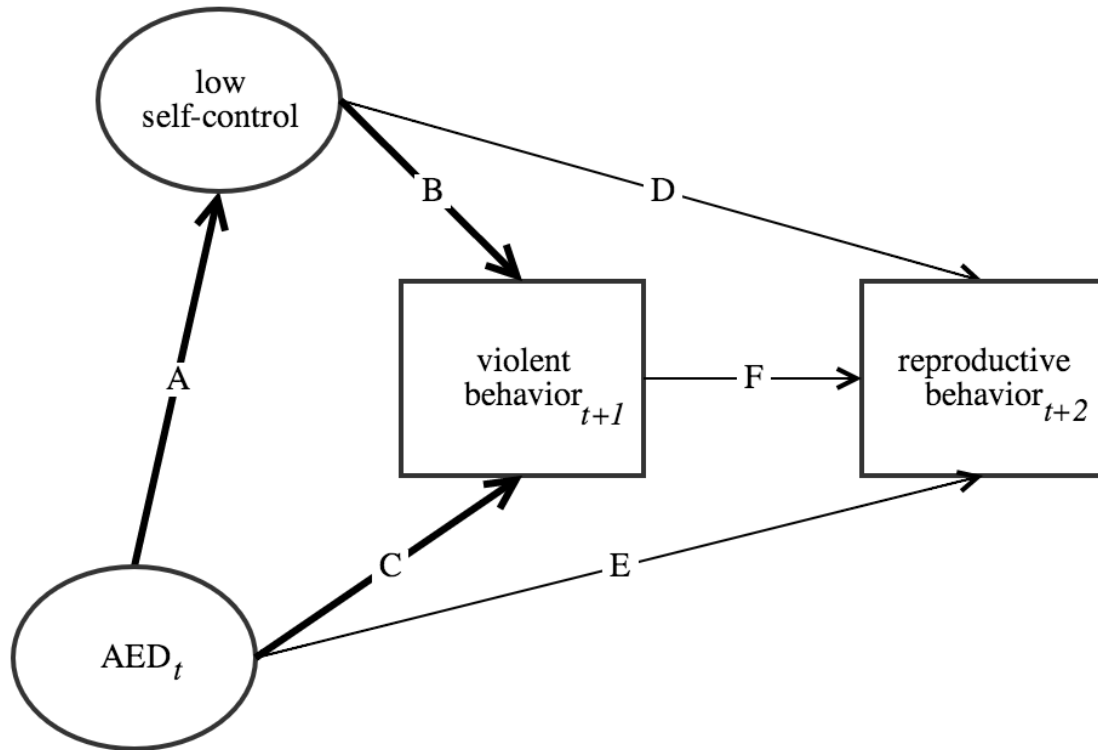

Figure 2.1. Theoretical Model of AED, Violence, and Reproductive Behavior

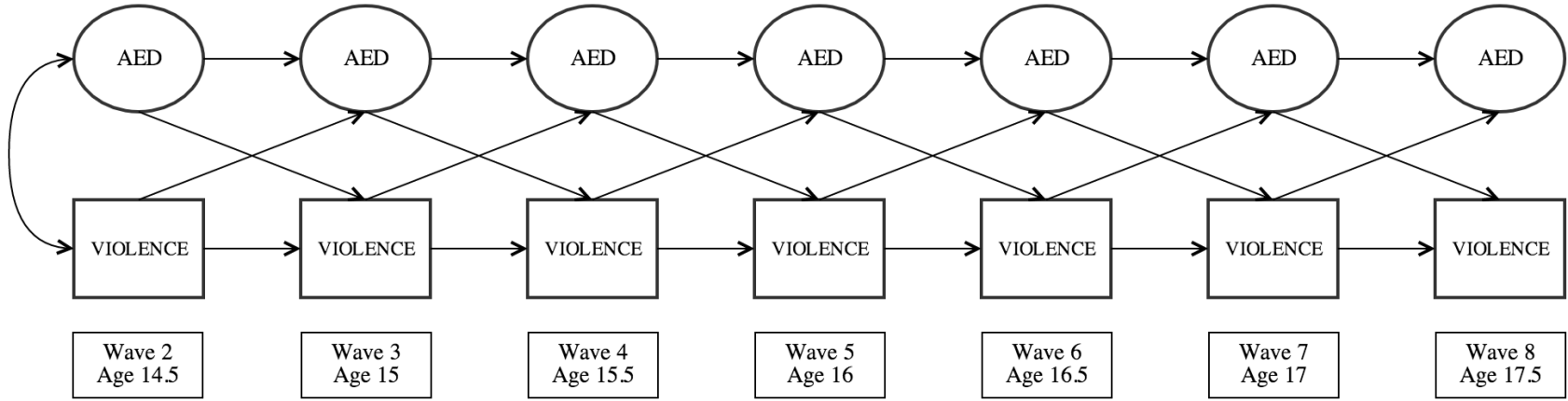

Figure 2.2. Cross-Lagged Model of AED and Risk-Taking Behavior

CHAPTER 3

Methods

To address the first project objective (“Operationalize a quantifiable measure of AED”), I use two longitudinal datasets, each with its own merits and limitations. As I describe below, the use of these two datasets enables me to evaluate the validity and reliability of the latent measures of anticipated early death.

Data and Samples

The National Longitudinal Study of Adolescent Health (Add Health).

First, I operationalize AED using the Add Health data, taking advantage of Add Health’s longitudinal design and direct measurement of AED. This study began in 1994 by interviewing a nationally representative sample of adolescents in seventh through twelfth grades. Four waves of data collection have followed the subjects into adulthood. Add Health researchers selected the sample using a school-based multistage cluster design. A questionnaire was administered to each student in attendance at the selected schools on a certain day in the 1994-1995 academic year. A random sample of about 200 students from each school was selected from school rosters to participate in the core sample for in-home interviews. Wave II follow-up in-home interviews were conducted in 1996. In 2001 and 2002, Add Health researchers conducted Wave III interviews on the Wave I respondents, to study transitions to adulthood.¹⁰

This dissertation uses publicly available Add Health data from Waves I through III. To ensure causal order in this study, I limit the sample to those who participated at all three waves of data collection. This results in a sample of 3,843 participants. The mean ages at Waves I and

¹⁰ For more detailed information about the Add Health project, see Harris (2011).

III are 15.10 and 21.43, respectively. Table 3.1 contains descriptive information for both the Add Health and RYDS datasets. Being nationally representative, the Add Health sample is primarily white (66%) and split almost evenly by sex (46% male and 54% female).

The Add Health dataset – a terrific resource due to the large sample size, its longitudinal design, and the heterogeneous sample – is commonly used in studies of AED (e.g., Borowsky et al., 2009; Brezina et al., 2009; Caldwell et al., 2006; Tillyer, 2015). Most importantly for this dissertation, Add Health actually contains two specific AED items.¹¹ In studies of AED, researchers typically use the measure evaluating one’s perceived chances of living to age 35. While Add Health measures my independent variable well, the survey does not adequately measure my dependent variables of interest. Although the dataset includes several items about violence, the Add Health questions about gang activity are insufficient for the purposes of this research – a key outcome of this study is gang involvement, and Add Health only asks about it at Waves II (“Have you been initiated into a named gang?”) and III (“Have you ever belonged to a gang?”), with no validating follow-up questions at either wave. Moreover, the data are inconsistent: of the 149 youth in the sample who reported having been initiated into a gang at Wave II, about two-thirds ($N = 95$) reported at Wave III (five years later) that they had actually never been in a gang. There is clearly some confusion among participants about what it means to have belonged to a gang. The scarce and conflicting information about gang involvement in the Add Health sample necessitates the use of an additional data source. I use the Add Health data to create a latent measure of AED, test its psychometric properties by comparing it with the direct

¹¹ “What do you think are the chances that each of the following things will happen to you?: You will be killed by age 21. You will live to age 35.” Possible answers range from 1 (almost no chance) to 5 (almost certain).

measure of AED, and then replicate the AED measurement model in the Rochester Youth Development Study data in order to study gang outcomes.

The Rochester Youth Development Study (RYDS).

To effectively measure gang and delinquency items, this study employs data from the RYDS. This allows me to more thoroughly address the second project objective (“Examine the impacts of AED on individual violence and gang activity, two extremely risky behaviors”).

The RYDS began in 1988 by interviewing 1,000 seventh- and eighth-grade students in the Rochester, New York public school system. By oversampling males and residents of census tracts with high resident adult arrest rates, researchers designed the study to sample youths at elevated risk of delinquency. To date, researchers have collected 14 waves of cohort interviews, following participants from ages 14 to 31, as part of this longitudinal study of delinquency.¹²

For this study, I use data from Waves 2 through 9, when respondents were between the mean ages of 14.43 and 17.88, respectively.¹³ During this time, the RYDS researchers interviewed subjects eight times (or waves) at six-month intervals.

Table 3.1 displays demographic statistics for the RYDS data, limited only to subjects who participated at all nine waves of data collection used in this dissertation. Because the RYDS team oversampled individuals at risk of delinquency, the sample is primarily male (72%). White youths are underrepresented in the RYDS data, accounting for just 15% of the sample. The remainder of the sample is 69% black and 16% Hispanic.

The Rochester Study’s focus on delinquency delivers a wealth of information about various delinquent behaviors, including in-depth information about specific instances of

¹² For detailed information about the RYDS design and methods, see Thornberry and colleagues (2003).

¹³ I do not use Wave 1 data because the first interview did not include a number of necessary variables (e.g., the depression measures). Subsequent interviews were more consistent.

offending to legitimize the responses. The gang data are particularly fertile, enough that the RYDS principal investigators published an entire award-winning book on gangs and delinquency based on the Rochester data (i.e., Thornberry et al., 2003). The availability of information about individuals' gang involvement, collected at six-month intervals throughout adolescence, is perfect for this dissertation with its goal of measuring AED's effects on gang activity.

Unfortunately, the RYDS data include no measures of AED. Creation and validation of an AED construct in the Add Health data, using measures that are also available in the RYDS data, provides a blueprint for creation of an AED construct in the RYDS. This process is detailed below.

Analytical Approach

In this dissertation, I first measure AED in the Add Health and RYDS data with second-order factor analysis. Next, I examine AED and violence in the Add Health data using structural equation modeling, and then replicate those analyses as closely as possible with the RYDS data. I extend the research in the RYDS data by examining the effects of the AED proxy variable on specific measures of gang activity that are unavailable in the Add Health data. Finally, I explore the temporal ordering of AED and risky behaviors using an autoregressive cross-lagged panel model. This section describes the methodology in detail.

Objective 1: Operationalize a quantifiable measure of AED.

There are many ways to create a measure for a latent variable (in this case, AED). I use factor analysis, which can operationalize latent variables by calculating the variance shared by observed measures (Rummel, 1967). Factor analysis requires a great deal of interpretation and judgment, necessitating a thorough grounding in theory. For the purposes of this dissertation, I factor analyze variables that are significantly related to AED in the literature (first-order factor

analysis), then create a factor variable that measures the shared variance of the AED correlates (second-order factor analysis).

I begin the analysis by identifying variables linked to anticipation of an early death and present in both the Add Health and RYDS datasets. These variables are described in the variable coding table in Appendix A. I describe them further later in this chapter, using Add Health's first wave of data as an exemplar to provide context. Using the two-pronged criteria of 1) research support for the variable as a correlate of AED and 2) availability of comparable measures in both Add Health and RYDS, I find several different constructs to include in the second-order factor analysis. In both datasets, constructs of depression, low self-esteem, attachment to parents, school connection, and low self-control (a mediating variable), are factor analyzed in the first-order factor analysis. The Add Health first-order factor analysis also generates a construct measuring poor academic performance, while the RYDS analysis creates a construct measuring negative neighborhood environment. Correspondingly, RYDS includes a single-item measure of poor academic performance and Add Health contains a single-item measure of negative neighborhood environment in the second-order factor analysis. Additionally, both datasets include single-item measures of parental unemployment and receipt of public assistance. Altogether, the second-order factor analyses include eight AED correlates from which a latent measure of AED is created for each observation period. Low self-control is also factor analyzed to serve as a potential mediator between AED and risk-taking behaviors.

After measurement of the AED proxy variables is complete, I evaluate the validity and reliability of the constructs. Because factor analysis relies strongly on theory and judgment it can be difficult to verify that the factors measure the desired latent concept. To address this shortcoming, I factor analyze AED in Add Health before computing proxy measures for AED in

the RYDS data. The fact that Add Health explicitly measures AED allows for substantiation of variables related to AED.

To measure the effectiveness of the Add Health factor analyses, I correlate the factor variables with the direct AED measures. Strong correlations between the factor variables and the explicit AED measures strengthen the validity of the newly created AED measures, indicating that the factor variables suitably approximate AED. I also evaluate the reliability of the AED factor variables by correlating them across waves. Strong correlations indicate that the factor variables reliably measure the same concept over time.

After identifying and confirming the variables related to AED in Add Health, I repeat the process to create proxy measures of AED for each wave in the RYDS data. Using variables that closely approximate those in the Add Health factor analyses, I conduct second-order factor analyses in the RYDS data. Because the RYDS data do not contain direct measures of AED, I cannot measure validity of the factor variables by correlating them with direct measures as I do with Add Health. However, as in the Add Health data, test-retest reliability is supported if the AED factor variables correlate strongly across waves.

In both datasets, to evaluate the validity of the new measures using the guiding framework of life history theory, I correlate the factor variables with measures of reproductive behavior. Based on the established life history theory research in psychology, medicine, and evolutionary biology, an effective measure of AED should correlate with both pregnancy and a greater number of sexual partners for those who discount the future. In this way, life history theory helps guide the measurement of AED. Chapter 4 explains the measurement and evaluation of the AED constructs in greater detail.

Objective 2: Examine the impact of AED on individual violence and gang activity.

In the bulk of the analyses in the chapters that follow, I employ Mplus statistical software for structural equation modeling with robust weighted least squares (WLSMV) estimation to evaluate the effects of AED on violence and gang involvement (L. K. Muthén & Muthén, 2007).¹⁴ I first conduct these analyses in the Add Health data and then replicate and expand with the RYDS data.

To begin, I estimate a two-wave structural equation model with the AED factor as the exogenous (i.e., independent latent) variable, low self-control as a mediator, and engagement in violence as the endogenous (i.e., dependent latent) variable. This allows me to measure AED's direct and indirect (through self-control) effects on violence. In Chapter 5, I complete these analyses for both Add Health and RYDS, for the full samples and for sex-separated subsamples to evaluate whether the process differs by sex. According to life history theory, AED should have a stronger effect on violence for males than females, because risky behavior, including violence, is evolutionarily advantageous for males with short time horizons (Alexander, 1979; Griskevicius et al., 2009; Sylwester & Pawłowski, 2011). For females, AED should increase the likelihood of reproduction, but not violence – females experience no reproductive advantage from violence (Gallup et al., 2011). To further explore these relationships in the context of life history theory, I estimate three-wave SEMs that add reproductive behaviors (that is, pregnancy and number of sexual partners) to the model. These models allow me to further evaluate the validity of the latent AED measures, beyond the correlations and Cronbach's alphas calculated after the measurement model in Chapter 4.

¹⁴ The robust weighted least squares approach is described in greater detail later in this chapter.

Chapter 6 focuses on gang activity; I therefore analyze RYDS data only. First, I estimate full-sample and sex-separated SEMs predicting gang membership by wave. Next, I estimate a negative binomial regression model to evaluate the impacts of AED and low self-control on the duration of gang membership, that is, the number of observation periods at which one reported gang membership. Because most RYDS subjects never reported gang membership and the non-normal frequency distribution is skewed toward zero, a negative binomial regression is most appropriate. Finally, I estimate stability of gang membership with a multinomial logistic regression. In this model, I measure the effects of AED and low self-control on category of gang membership stability: short-term (one wave only), intermittent (multiple waves of membership, with a break in between), and long-term gang membership (one period of consecutive waves of gang membership). These three categories (as well as the reference category of nongang youth) are mutually exclusive nominal classifications, making multinomial logistic regression the most appropriate technique for this analysis. The negative binomial and multinomial logistic regression models are described in greater detail in Chapter 6.

Objective 3: Determine the causal ordering of AED and delinquent risk-taking behaviors (i.e., violence and gang activity).

In meeting the second project goal (described in the prior section), I estimate structural models measuring the effects of AED on violence and gang membership one wave later. These models test the theory that AED encourages adolescents to engage in risk-taking behaviors because they believe they have nothing to lose or (perhaps unconsciously) in order to improve their chances of reproduction, per life history theory. However, the reverse may also occur – youths may experience fatalistic beliefs because of their engagement in dangerous and risky behaviors.

Prior research has found reciprocal effects between AED and risky health behaviors – AED predicted later risky health behaviors (i.e., drug use, suicide attempt, fight-related injury, police arrest, unsafe sex, and HIV diagnosis) and vice versa (Borowsky et al., 2009). A key benefit of the RYDS data is the large number of waves of data, collected from a sample of at-risk youth at six-month intervals throughout the teen years. The use of so many waves of data, especially collected so close in time, enables a better understanding of how AED and risky behaviors change and influence each other over time. To further examine this relationship and meet my third project goal, I employ autoregressive cross-lagged panel models using waves 2 through 9 of the RYDS data. As with the previous SEMs, I estimate the models using the Mplus 5 software program (L. K. Muthén & Muthén, 2007).

An autoregressive cross-lagged panel model assesses the effect of one construct on another measured at a later time, accounting for previous levels of the dependent variable (Selig & Little, 2012). In the context of my dissertation, I estimate the effect of risk-taking behaviors at wave t on AED at wave $t+1$, and vice versa – this is the cross-lagged portion of the model. The autoregressive component of the model controls for the effect of each variable at one period on the same variable at the next period (e.g., the effect of AED_t on AED_{t+1}). Additionally, the model estimates the correlation between the variables at the first wave in the model. The autoregressive component of the model allows the researcher to rule out the likelihood that an apparent cross-lagged effect actually result from a correlation between the two variables at the initial observation period (Selig & Little, 2012, p. 266). Analysis of such a rich longitudinal dataset with this sophisticated model provides a valuable contribution to the literature on causal ordering in AED and risk-taking behavior.

Observed Variables

This section describes the variables employed in the analysis. I selected the indicators used in the factor analysis based on the literature surrounding AED as a dependent variable (reviewed in Chapter 1). I omit variables measuring risky behaviors from the factor analysis because the premise of this dissertation is to explore the effects of AED on risky behaviors; it would therefore be inappropriate to include risky behaviors in the measurement of the independent variable.¹⁵

Appendix A contains a table describing the variables included in the dissertation; it provides a column for the Add Health measures alongside a column for the RYDS measures. The variables are described below. Due to the sheer volume of data and variables employed in this dissertation, I use one wave (Add Health Wave I) as an exemplar in this chapter to describe the variables. I provide the descriptive statistics for the RYDS (wave 2) variables in Appendix B. Descriptive statistics for any other measures employed in the dissertation are available upon request. In addition to describing the data for Add Health Wave I, I also note any substantial differences in variables across observation periods. The variables are generally stable from wave to wave.

Table 3.2 provides the sample size, mean, standard deviation, and range for the observed variables in the Add Health first-order factor analysis. Each of the first-order constructs is factor analyzed from several individual survey items. For both the Add Health and RYDS datasets, the items in each construct are selected based on prior research, most often items other researchers have used to create a scale.

¹⁵ Of course, perhaps engagement in risky behaviors contributes to AED; this possibility is explored with reciprocal analyses in Chapter 7.

At the individual psychological level, youths with depression (Tillyer, 2015), low self-esteem (Duke, Borowsky, et al., 2011; Duke et al., 2009; Duke, Skay, Pettingell, & Borowsky, 2011), or decreased levels of connectedness to their families, schools, peers, and communities (Bolland et al., 2005; Caldwell et al., 2006; Duke et al., 2009) are more likely to anticipate an early death. In the dissertation, *depression*, *low self-esteem*, *low attachment to parents*, and *low connection to school* are operationalized in the first-order factor analysis in the measurement model.

As Table 3.2 demonstrates, the depression construct factor analyzes 18 individual items. The items have a Cronbach's α of .86, indicating that the items measure the same concept (Cortina, 1993). The Add Health depression items are very similar to the RYDS items (Appendix A). Scales created from the items in each dataset have a long history of use in prior research. The same is true of the low self-esteem items, which have a similarly high Cronbach's α (.83) in the Add Health data.

With 11 varying items, the RYDS contains more questions relating to parental attachment (Appendix A). However, the four items in the Add Health survey perform sufficiently well ($\alpha = .74$) in measuring subjects' feelings of closeness and attachment to their parents. The final individual psychological measure, low school connection, also includes only four items in the Add Health data. A scale containing these items doesn't perform as well as the others discussed thus far; the Cronbach's α for these variables is .69, just below the commonly-used .70 threshold. This is due to the item regarding one's desire to attend college; an overwhelming majority of the Add Health sample (72%) expressed a strong desire to attend college. Removing this question would increase the alpha to .78. However, because this item measures anticipation of future events, it is important to include in the model.

On a related note, *poor academic performance* is also linked to AED as an indicator of future opportunity for conventional success (Caldwell et al., 2006; Duke et al., 2009). Measurement of this variable differs between the two datasets I use. In the Add Health data, I measure poor academic performance by factor analyzing subjects' grades in English, math, science, and social studies ($\alpha = .75$). In the RYDS data, this is measured using subjects' official math scores on the California Achievement Test (CAT). Specifically, the variable represents the reverse-coded percentile, so low-scoring individuals rate highly on this measure of poor academic performance. This variable was chosen because RYDS researchers have employed it in the past and found that math performance was a somewhat better predictor of delinquency than was the CAT reading score (Thornberry et al., 2005).

Scholars have also linked some family characteristics to AED. Tillyer (2015) and Borowsky and colleagues (2009) found that adolescents whose families *received public assistance* were more likely to anticipate an early death, and other studies have found that adolescents with *unemployed parents* are more likely to expect to die early (Duke et al., 2009; DuRant et al., 1994). These two variables are measured in both Add Health and RYDS with binary variables. In both samples, 6% of the subjects' parents reported unemployment at the time of the interview. The datasets differ, though, on public assistance receipt. Whereas only 10% of the Add Health subjects reported that their parents received some form of public assistance, nearly half (44%) of the RYDS participants reported the same. This is likely a function of each project's respective sampling procedure. Add Health assembled a nationally representative sample while RYDS focused on youth at risk of delinquency, based on adult resident arrest rates by census tract. Due to the interrelated nature of offending and poverty, a greater proportion of the RYDS participants receive public assistance.

Most studies of AED operate at the individual level, but community characteristics may influence fatalism as well. In a study conducted at the neighborhood level, Wilson and Daly (1997) concluded that low life expectancy in the neighborhood resulted in residents discounting the future. Similarly, those who live in neighborhoods with physical and social disorder anticipate dying at young ages (Piquero, 2016). For these reasons, I include a measure of *negative neighborhood environment*. The Add Health data contain an item measuring how safe the subject feels in his or her neighborhood; this is employed here as a dichotomous variable coded 1 if the respondent reports living in an unsafe neighborhood. The RYDS data contain many more neighborhood variables. Here, I factor analyze 17 items about neighborhood disorganization to create the negative neighborhood construct in the RYDS first-order factor analysis (see Appendix A). These items have some limitations – questions were only asked of the participants’ parents (G1s), so they are not respondents’ self-reports. Also, the questions were asked only if the parent reported having moved to a new neighborhood since the last interview. For waves at which the neighborhood questions were skipped because the family had not moved, the previous wave’s responses are carried over.

The variables described in this section are ones that prior research has shown to be related to AED. Additionally, they are concepts for which the Add Health and RYDS datasets have comparable measures. This allows me to estimate the measurement models with confidence that I am quantifying the same construct in both datasets.

In addition to AED, I include measures of *low self-control* to test whether it mediates the relationship between AED and risky behavior. Low self-control is a strong predictor of delinquency for both males and females (LaGrange & Silverman, 1999). It is also related to risky sexual behavior for both sexes, although females generally have higher levels of self-control –

and, consequently, lower levels of risky sexual behavior – than males (Hope & Chapple, 2004). I create a latent measure of low self-control using first-order factor analysis in both the Add Health and RYDS datasets. The six questions included in the RYDS measure were asked only at wave 10, when subjects were about 21 years old. Given the declaration by Gottfredson and Hirschi (1990) that self-control is a stable characteristic, it is appropriate to use this measure throughout the analyses. The Add Health measure of self-control emulates one created for use in the Add Health data by Perrone and colleagues (2004). Both datasets' self-control measures emphasize temper and impulse control.

The final section of Table 3.2 describes *violence prevalence*, the only observed measure that serves as a dependent variable in the Add Health structural models. This is a binary variable coded 1 if a participant reports having engaged in at least one of five behaviors: using a weapon in a fight; taking part in a serious physical fight; taking part in a fight where a group of the respondents' friends was against another group; using or threatening to use a weapon to get something from someone; physically forcing someone to have sex against her will (this question was asked of males only). The mean of this variable is .30, indicating that 30% of the sample report engaging in at least one violent behavior at Wave II.

Because I use RYDS to estimate the bulk of the structural models, there are several dependent variables in the RYDS data (Appendix A, Appendix B). Violence prevalence measures whether one reported engaging in at least one violent behavior (i.e., hitting someone with the idea of hurting them; attacking someone with the idea of seriously hurting or killing them; involvement in gang fighting; throwing objects at people; using a weapon or force to get something from someone; physically hurting or threatening to hurt someone to get them to have sex) at wave 2. Similarly to the Add Health data, 28% of the sample reports engaging in at least

one violent behavior at wave 3. Prevalence of violence declines over time; just 13% of RYDS participants report any violence at wave 9 (age 18).

To better measure seriousness of violent offending, I examine whether AED impacts the variety of violent acts in which one engages. Klein (1995) and others (e.g., Melde & Esbensen, 2013; Thornberry et al., 2003) have found that adolescent offenders and gang members in particular are more likely to show versatile (“cafeteria-style”) offending patterns than specialization in one type of crime. *Violence variety* is a count of how many different types of violent behaviors a subject reported engaging in at each observation period. For example, a subject who threw objects at people and took part in gang fighting is coded 2. The variable mean of 0.42 indicates that, on average, respondents engage in few different types of violent crime at wave 3 – most do not report any acts of violence.

Gang membership is measured at each wave with a question asking if the participant was a member of a street gang or posse since the last interview. This dichotomous variable’s mean of .12 indicates that 12% of the RYDS sample report gang membership at wave 3. Participation in gangs declines as the sample ages – at wave 2, when the gang question is first asked, 14% ($N = 116$) report gang involvement. The number falls to 3% ($N = 28$) by wave 9.

Nearly a third of RYDS participants report gang membership in at least one interview ($N = 231$, 29%). However, of those who are gang-involved at any time, most are in the gang for a short period. *Gang duration* is equal to the summed number of waves at which one reports gang membership. The descriptive statistics for this variable presented in Appendix B represent the entire RYDS sample; the mean of 0.62 indicates that on average, subjects report little or no gang involvement. The mean number of waves of gang membership is 2.16 amongst gang-involved members of the RYDS sample, indicating that most gang members spend only about two waves

in the gang. This demonstrates that gang membership is not a lifelong commitment for RYDS youths.

The final dependent variable in the RYDS data is *stability of gang membership*. This variable includes four categories: nongang youth; short-term gang members; intermittent gang members; long-term gang members. Nongang youth report no gang membership at any point from waves 2 through 9. Short-term gang members report gang membership only at one observation period. Long-term gang members report multiple consecutive waves of gang membership, and do not report leaving the gang more than once (that is, once they leave the gang they do not rejoin). The category for intermittent gang membership includes those respondents who report gang membership at multiple waves, but with a break in between. In its battery of gang questions, the RYDS survey asks whether the respondent is still in the gang. Individuals are coded as intermittent gang members if they report gang membership in nonconsecutive waves or if they say they have left the gang, but report gang membership at a subsequent wave.

Most RYDS participants (71%) are never in a gang. Of those who are, most report gang membership during a single observation period. Just 6% ($N = 48$) of the total RYDS sample are long-term gang members; the average number of waves in the gang for this category is 2.58. Surprisingly, the 82 intermittent gang members report more gang involvement than the “long-term” gang members – an average of 3.35 waves. This indicates that those who repeatedly join gangs may ultimately spend more time in the gang than those who join the gang for one lengthy period.

Missing Data and Structural Equation Modeling

Item response rates are high for both the Add Health and RYDS datasets. In the Add Health data, most items in the analysis are missing data for 0 to 2% of cases. A few variables are

missing data for many cases, though. In particular, at both waves, the two variables measuring attachment to the respondent's father are missing 26% to 27% of cases. The academic performance indicators are also missing data – up to 12% at Wave I and up to 22% at Wave II. This is expected as respondents age out of the education system. The other variable missing over 10% of cases is parent unemployment, for which 11% of cases are missing.

For the RYDS data, item response rates are high and attrition is low. In a study of attrition in the RYDS sample, Krohn and Thornberry (1999) found no significant differences between subjects retained by Wave 10 compared to those who had ceased to participate in the study. Additionally, Krohn and Thornberry found that the retention rate by Wave 10 was 87%, quite high for such an intensive longitudinal study of an at-risk population. This is important to note because this dissertation uses data from nine waves, spanning about four years.

As in the Add Health data, most items in the RYDS analysis are missing data for 0 to 2% of cases. The items measuring school connection have the largest amount of missing data, increasing as the individuals age. In wave 2 (about age 14.5), less than 1% are missing data on the school items but by wave 8 (age 17.5), 20% of cases are missing. The items measuring academic performance also have an increasingly large amount of missing data – 14% at wave 2, up to 43% at wave 8.

Available case analysis with robust weighted least squares.

I use the Mplus 5 statistical program to estimate structural equation models. Because most variables in my models are categorical, the program employs a mean- and variance-adjusted weighted least squares (WLSMV) estimator that Muthén and colleagues (1997) recommend for large latent variable analysis models with categorical measures. This approach is preferred over traditional weighted least squares (WLS) because this specification uses a

diagonal weight matrix with standard errors that use a full weight matrix (B. O. Muthén, du Toit, & Spisic, 1997). It produces robust standard errors and allows for chi-square model testing.

Muthén and colleagues (1997) found that WLSMV performs as well as a generalized estimating equation (GEE) approach, but demands much less computational time and effort.

In a model with no covariates (e.g., the models estimated in this dissertation), WLSMV uses a two-stage process that is equivalent to available case analysis (L. K. Muthén & Muthén, 2012). In other words, cases with missing data are kept and used in all analyses except those requiring the specific variables that are missing. Only subjects with data missing on all variables are deleted from the analysis.¹⁶ Pairwise present analysis can yield biased estimates, but Graham (2009, p. 554) reported that “the biases tend to be small in empirical data.” Asparouhov and Muthén (2010) found that WLSMV produces unbiased results for both the parameter estimates and the standard errors when the data are missing completely at random.

In addition to concerns about bias, another potential problem with available case analysis is that, because the correlations are based on different subsamples, the covariance matrix is sometimes not positive definite, meaning that the analysis cannot be completed (Graham, 2009). This occurs when the matrix cannot be inverted or when the determinant of the matrix is zero; it can be caused by collinear observed variables (Schumacker & Lomax, 2010). Fortunately, Mplus returns an error message if the covariance matrix is not positive definite; this is not a problem in the dissertation analyses.

The ideal way to manage missing data in both the Add Health and RYDS datasets would require structural equation modeling with maximum likelihood (ML) estimation. This method produces consistent and efficient estimates (Allison, 2003). Alas, ML estimation in Mplus 5 is

¹⁶ In this dissertation, only one case was deleted (from Add Health, Wave II) due to missing data on all variables.

not possible for models that test indirect effects, as I do. Moreover, the models I estimate are too computationally intensive for Mplus to accommodate with ML, even without indirect effects. Another common technique for dealing with missing data is multiple imputation, which “has statistical properties that are nearly as good as maximum likelihood” (Allison, 2003, p. 81). Beginning with version 6, Mplus offers the capability to conduct multiple imputation of data prior to WLSMV analysis. Regrettably, I only have access to Mplus 5. Given these limitations in the available statistical software, pairwise deletion is the best way to manage missing data in this project.

Summary

This chapter has provided a general overview of the data and analytical techniques I use in this dissertation. To meet my first project objective of creating a novel measure of anticipated early death, I employ data from the National Longitudinal Study of Adolescent Health as well as the Rochester Youth Development Study. Using comparable variables in the two datasets, I estimate second-order factor analyses to create latent measures of AED.

To achieve the second project objective, I estimate structural equation models to explore the relationships between AED and risk-taking behaviors. Specifically, the models measure the ways in which AED directly and indirectly (via low self-control) impacts violent offending and gang activity.

The final project objective is realized by estimating autoregressive cross-lagged panel models using eight waves of the RYDS data, spanning ages 14.5 to 18. I conduct these analyses with a goal of determining whether AED precedes risk-taking behavior (because individuals feel they have nothing to lose) or if risky behavior precedes AED (likely because engaging in dangerous activity contributes to one’s expectation of an early death).

I describe the measures and analyses in greater detail in the results chapters, beginning with the measurement models in Chapter 4.

Table 3.1. Demographic Statistics for Add Health and RYDS Samples

	Add Health		RYDS	
<i>N</i>	3843		804	
Percent Male	46		72	
Percent Female	54		28	
Percent White	66		15	
Percent Black	23		69	
Percent Hispanic	11 ^a		16	
Percent Native American	2		---	
Percent Asian	4		---	
	Mean	Range	Mean	Range
	(SD)		(SD)	
Age (first wave)	15.10 (1.62)	11.0 – 21.0	14.43 (0.77)	11.9 – 16.2
Age (last wave)	21.43 (1.30)	18.0 – 27.0	17.88 (0.80)	15.3 – 19.9

^a Although the other four race categories in the Add Health data are mutually exclusive, “Hispanic” is measured separately as an ethnicity. It is therefore possible for subjects to report being Hispanic and also being white, black, Native American, or Asian. This is why the Add Health race/ethnicity percentages sum to 106.

Table 3.2. Add Health Observed Variables Descriptive Statistics, Wave I

		<i>N</i>	Mean	SD	Range
<i>AED direct measure</i>					
	What do you think are the chances that you will live to age 35? (R)	3829	1.61	0.85	1 - 5
Indicators in First-Order Factor Analysis					
<i>Depression</i> [$\alpha = .86$]					
	You were bothered by things that usually don't bother you.	3836	0.47	0.67	0 - 3
	You didn't feel like eating, or your appetite was poor.	3839	0.45	0.70	0 - 3
	You felt that you could not shake off the blues, even with help from your family and your friends.	3837	0.36	0.68	0 - 3
	You felt that you were just as good as other people.	3836	1.06	1.01	0 - 3
	You felt depressed.	3836	0.49	0.73	0 - 3
	You felt that you were too tired to do things.	3838	0.72	0.74	0 - 3
	You felt hopeful about the future. (R)	3832	1.16	0.99	0 - 3
	You thought your life had been a failure.	3835	0.19	0.52	0 - 3
	You felt fearful.	3837	0.32	0.57	0 - 3
	You were happy. (R)	3838	0.85	0.79	0 - 3
	You talked less than usual.	3839	0.55	0.74	0 - 3
	You felt lonely.	3836	0.44	0.70	0 - 3
	People were unfriendly to you.	3838	0.40	0.63	0 - 3
	You enjoyed life. (R)	3838	0.74	0.85	0 - 3
	You felt sad.	3839	0.55	0.68	0 - 3
	You felt that people disliked you.	3837	0.42	0.66	0 - 3
	It was hard to get started doing things.	3838	0.59	0.65	0 - 3
	You felt life was not worth living.	3836	0.15	0.47	0 - 3
<i>Low self-esteem</i> [$\alpha = .83$]					
	You have a lot of good qualities. (R)	3833	1.73	0.66	1 - 5
	You are physically fit. (R)	3834	2.11	0.92	1 - 5
	You have a lot to be proud of. (R)	3833	1.68	0.70	1 - 5
	You like yourself just the way you are. (R)	3836	2.01	0.96	1 - 5
	You feel socially accepted. (R)	3833	1.91	0.76	1 - 5
	You feel loved and wanted. (R)	3836	1.69	0.70	1 - 5

		<i>N</i>	Mean	SD	Range ₁
...Table 3.2 continued...					
<i>Low attachment to parents</i> [$\alpha = .74$]					
	How close do you feel to [mother]? (R)	3666	1.43	0.76	1 - 5
	How much do you think she cares about you? (R)	2799	1.14	0.47	1 - 5
	How close do you feel to [father]? (R)	3668	1.69	0.94	1 - 5
	How much do you think he cares about you? (R)	2799	1.23	0.60	1 - 5
<i>Low school connection</i> [$\alpha = .69$]					
	You feel close to people at your school. (R)	3781	2.25	0.98	1 - 5
	You feel like you are part of your school. (R)	3783	2.13	1.00	1 - 5
	You are happy to be at your school. (R)	3781	2.29	1.13	1 - 5
	How much do you want to go to college? (R)	3829	1.53	0.99	1 - 5
<i>Poor academic performance</i> [$\alpha = .75$]					
	At the most recent grading period, what was your grade in English or language arts?	3687	2.14	0.95	1 - 4
	At the most recent grading period, what was your grade in mathematics?	3627	2.28	1.03	1 - 4
	At the most recent grading period, what was your grade in history or social studies?	3401	2.05	1.00	1 - 4
	At the most recent grading period, what was your grade in science?	3455	2.10	0.99	1 - 4
<i>Parental unemployment</i>					
	[Parent report]	3436	0.06	0.24	0 - 1
<i>Public assistance receipt</i>					
	Does [mother/father] receive public assistance, such as welfare?	3771	0.10	0.30	0 - 1
<i>Negative neighborhood environment</i>					
	Do you usually feel safe in your neighborhood? (R)	3831	0.10	0.30	0 - 1
<i>Low self-control</i> [mediator] [$\alpha = .70$]					
	You had trouble keeping your mind on what you were doing.	3837	0.80	0.81	0 - 3
	You feel like you are doing everything just about right. (R)	3835	2.24	0.88	1 - 5
	Since school started this year, how often have you had trouble:				
	Getting along with your teachers?	3783	0.93	1.00	0 - 4
	Paying attention in school?	3783	1.21	1.02	0 - 4
	Getting your homework done?	3783	1.14	1.06	0 - 4
	Getting along with other students?	3783	0.89	0.96	0 - 4

	<i>N</i>	Mean	SD	Range
...Table 3.2 continued...				
	Dependent Variable ^a			
<i>Violence Prevalence</i>				
[Subject reports engaging in at least one of five violent behaviors – see Appendix A]	3836	0.30	0.46	0 - 1

^a Dependent variable is measured at Wave II.

(R) = reversed item

Note: For dichotomous variables, the mean presents the percentage of respondents coded 1 on that variable. For example, the mean of “unsafe neighborhood” is 0.10, indicating that 10% of the respondents felt that they lived in an unsafe neighborhood.

CHAPTER 4

Measurement of Anticipated Early Death

I begin the analysis by measuring anticipated early death and its effects on the dependent variables using structural equation modeling. Within a single model, SEM allows one to hypothesize how constructs are defined by sets of variables, and how these latent measures relate to one another, while accounting for measurement error in the latent constructs (Schumacker & Lomax, 2010). As Figure 4.1 illustrates, the model I estimate consists of a second-order factor analysis to measure AED, as well a structural component wherein I measure the effects of AED on the outcome variables. Using SEM, I test the theoretical model and determine the degree to which the model is supported by data from two contrasting samples. To accomplish this, I use the Mplus 5 statistical software package (L. K. Muthén & Muthén, 2007).

The use of Mplus for SEM is especially beneficial for the purposes of this dissertation because, unlike many other SEM programs, Mplus allows estimation of models with non-normal, non-continuous, and missing data (Muthén & Muthén, 2012, p. 7). Because most variables in my models are categorical, the program utilizes a robust weighted least squares (WLSMV) estimator that Muthén and colleagues (1997) recommend for large latent variable analysis models with categorical measures. The WLSMV estimator produces robust standard errors and allows for chi-square model testing.

The observed variables used in the second-order factor analysis are described in Chapter 3, Table 3.2, and Appendix A.

Add Health

As described in Chapter 3, I first estimate the structural equation models for the Add Health data. To measure AED in Mplus, I conduct a second-order factor analysis, wherein the components of the AED factor variable are themselves factor variables. Figure 4.1 illustrates this process for both Add Health and RYDS.

Appendix A supplies a list of variables used in the study, describing the measures in each dataset. Table 3.2 provides descriptive statistics for the observed variables used in the measurement of the AED components (i.e., the first-order factor analyses), described in the prior section. The process of using two longitudinal datasets to factor analyze a latent variable presents the challenges of matching variables in both datasets and matching across waves within the datasets. The variables included in this study are selected based on the AED literature and with the goal of inclusion of similar measures from both datasets. Each dataset lacks some measures that likely predict AED – for example, the Add Health data do not include community Census measures and the RYDS data contain no victimization information. For the dissertation analysis, I use factor variables in both datasets created with identical or similar measures – that is, factor analysis in each dataset is limited by availability of measures in the other dataset.

Second-order factor analysis exemplar.

The second-order factor analysis allows me to create a latent construct of AED by measuring the shared variance in several correlates of AED, as illustrated in Figure 4.1. For this measurement step, I use the Mplus 5 structural equation modeling program. The first-order model factor analyzes several observed variables to measure latent constructs: depression, low self-esteem, low attachment to parents, low school connection, and poor academic performance.

These factor variables are then themselves factor analyzed to create a second-order latent construct: anticipated early death.

To estimate the model, I begin by including in the second-order factor analysis all variables available in both the Add Health and RYDS datasets and also linked to AED in the literature. I then modify the model to better specify measurement of the latent variable: with each iteration, I remove the variables with factor loadings of less than .30 because a loading below this cutoff value indicates that less than 10% of the measure's variance is due to the latent variable (Rummel, 1967).¹⁷ Researchers often use the loading cutoff value of .30 for this reason. All of the observed variables in the first-order factor analysis component of the model easily meet the .30 cutoff, so none are removed from the model.¹⁸ This is expected given that the variables included in the measurement of the individual components are drawn from previous research using each dataset. In a typical regression analysis, the individual components would be measured by scales including the items used here.

Table 4.1 illustrates the variable narrowing process undertaken to create the best measurement of AED. Model 0 includes Add Health's direct AED measure, the "die by age 35" variable. This is done to ensure that it loads strongly with the other variables, indicating that the variables in the model are in fact related to AED as it is explicitly measured. The standardized coefficient for the direct AED measure is .42, indicating that 18% of the variation in the direct AED measure is due to the unobserved factor variable ($.42^2 = .18$). Model 1 contains the same variables as Model 0, except that the "die by 35" measure is removed so the latent variable

¹⁷ Post hoc model modification capitalizes on chance and, due to the data-driven nature of the model, may result in a model that is not generalizable (Weston & Gore Jr., 2006). However, because modifications are limited to those that are theoretically acceptable, because I will next use the latent variable as an independent variable in further models, and because I will replicate analyses with a second, very different, sample, post hoc modification is appropriate here.

¹⁸ The results of the first-order factor analyses are not displayed here, but are available upon request. -

measurement can begin in earnest. In Model 1, only parent unemployment fails to meet the loading cutoff value of .30. With a loading of just .16, only 3% of the variation in parent unemployment is due to the latent variable. To begin the iterative model-narrowing process, I remove parent unemployment. Without this variable, the coefficients in Model 2 largely remain the same; the smallest loading of the remaining variables is .33, for unsafe neighborhood, indicating that 11% of the variance in the neighborhood variable is due to the latent measure. All variables in Model 2 meet the criteria, so no further restriction is necessary for Add Health's Wave I data. In the final model, low self-esteem is the most strongly related to the latent AED measure, with its loading of .80 indicating that 64% of the variation in low self-esteem is accounted for by the latent variable.

The model fit statistics suggest that the model is an acceptable fit for the data. The χ^2 value of 4866 is significant, indicating that the model does not perfectly fit the data. However, the χ^2 test is sensitive to sample size and consequently almost always rejects the model (Iacobucci, 2010), so a significant χ^2 value alone does not warrant dismissal of the model. The Tucker-Lewis index (TLI) value of .94 for Model 2 is greater than the generally accepted .90 cutoff value, indicating a good model fit (Schumacker & Lomax, 2010). The root mean square error approximation (RMSEA) value of .07 is less than .08, indicating a reasonable fit (Schumacker & Lomax, 2010). Although the significant χ^2 value recommends rejection of the model, the TLI and RMSEA suggest an acceptable fit. There exists a great deal of debate about SEM fit indices, ranging from what an appropriate cutoff value is to consideration of whether fit indices should be reported at all (Hooper, Coughlan, & Mullen, 2008). As Hooper and colleagues emphasize, allowing model fit to drive the research process shifts research away from theory

testing (2008, p. 57). Because the model I present here is firmly guided by theory and existing research, I do not adjust the models in search of improved fit statistics.

I used the iterative modification process just described and illustrated in Table 4.1 to measure AED for Waves I and II of the Add Health data and waves 2 through 8 of the RYDS. Because the process is so cumbersome, I will not describe it in such great detail for all the other waves. Instead, I present only the loadings and model fit statistics for the final models for each wave.

Table 4.2 provides the factor loadings and goodness-of-fit statistics for the second-order model in both Waves I and II of the Add Health sample. The results for Wave I are also shown in Table 4.1 and are described above. The loadings for Wave II are quite similar to the Wave I loadings. The only major difference between the two waves' models is that living in an unsafe neighborhood is not strongly related to the other variables in Wave II. In both models presented in Table 4.2, depression, low self-esteem, and low school connection have the largest loadings, indicating that these variables are the most strongly related to AED in the Add Health sample. The fit statistics for the two waves' models are essentially identical. Given the TLI values of .94 and the RMSEAs of .07, I conclude that the models fit the data acceptably.

Differences by sex.

I also estimate the second-order factor analyses by sex, to determine whether different factors are crucial in the measurement of future discounting for the two sexes.¹⁹

Table 4.3 presents the final model loadings and fit statistics for both Waves I and II, by sex. The most obvious difference between the two groups is that living in an unsafe

¹⁹ I use the term "sex" instead of "gender" here because both the Add Health and RYDS interviews refer to respondents' biological sex. These variables are based upon the interviewers' observations, though, and the surveys include instructions for the interviewer to verbally confirm sex "if necessary."

neighborhood loads for females but fails to reach the .30 criteria for males. There are otherwise no major differences in measuring AED for males and females separately. The loadings in the female sample are generally larger than the males' loadings, but not tremendously so. In both subsamples low self-esteem has the largest loadings, ranging from .74 (Wave II females) to .79 (both males and females at Wave I).

The model fit statistics for the four models in Table 4.3 are very similar, and are similar to the fit statistics for the entire Add Health Sample. The TLIs ranging from .93 to .95 and the RMSEAs ranging from .06 to .07 place the models within the acceptable range.

Evaluation of reliability and validity.

Given the strong conceptual foundation supporting the relationships between the latent measure and the observed variables in the factor analysis, I am confident that the iterative factor analysis measures future discounting, as intended. To further support this claim, though, I evaluate the psychometrics of the created factor variables.

A common way to test the reliability of a factor analysis is by computing the Cronbach's alpha for the indicators in the model. To do this, I calculate the alpha using the constructs created by the first-order factor analysis (i.e., the factors for depression, low self-esteem, etc.). In this case, $\alpha = .76$ for both Waves I and II. The general rule for Cronbach's alpha is that a value of .70 or greater supports reliability of the measure (Cortina, 1993); the values here meet this criteria.

To evaluate the effectiveness of the AED measurement model, I examine the bivariate relationships between the direct AED measures and the factor variables created in the measurement model. Table 4.4 displays the bivariate correlations between the latent variables and the direct AED measures, for both Waves I and II. Although Add Health contains two questions measuring AED ("What are the chances you will be killed by age 21?" and "What are

the chances you'll live to age 35?"), I have chosen to use only the item measuring one's perceived chances of living to age 35. The "killed by 21" item is fascinating but connotes a violent death caused by assault or accident. Also, most other studies have defined AED according to one's perceived chances of dying by age 35. For these reasons, this dissertation uses that measure only. However, I have reverse-coded it and refer to it as a variable measuring perceived chances of "dying by age 35" rather than "living to age 35."

Because most of the variables used in the factor analysis are not normally-distributed continuous variables, Pearson correlations are inappropriate for many of these relationships. Instead, I calculate polychoric, polyserial, or Pearson correlations as appropriate (i.e., polychoric correlations for relationships between two ordinal variables, polyserial correlations for relationships between ordinal and continuous variables, and Pearson correlations for continuous variables) using Stata's user-written POLYCHORIC command (Kolenikov, n.d.). This command does not compute significance tests, but many of the correlations in Table 4.4 are greater than .20, indicating moderately strong relationships.

The AED factor variables and direct measures have a correlation of .34 at Wave I and .35 at Wave II, signifying a moderately strong relationship between the direct AED measures and the factor variables created to serve as a proxy for future discounting. This indicates that the second-order factor analysis created a satisfactory measure of the AED latent variable.

To further measure predictive validity of the factor variable, I correlate the indirect and direct AED measures with some of the delinquency measures available in the Add Health data. These variables are all dichotomous, as described in Appendix A. The violence prevalence variables are coded 1 if the subject reported one or more of these activities: using a weapon in a fight, getting into a serious fight, group fighting, robbery, or, for Waves I and II (males only),

rape. The AED direct and factor variables are similarly predictive of these outcome behaviors at both Waves I and II. This further promotes the validity of the AED factor variable.

To evaluate the validity of the measure using my guiding framework of life history theory, I correlate the AED factor variables and the direct measures with measures of reproductive behavior at the same wave and at the following wave. The reproductive behavior variables measure the number of sexual partners a subject reported having and whether the subject had ever been pregnant (if female) or impregnated someone (if male). The correlations for the pregnancy variables are all greater than .20, while the correlations for number of sexual partners start high in Wave I (.24 and .20) and decline by Wave III to .07 for WI AED and .05 for WII AED. This is likely due to a lack of variability in the sample by Wave III. In Waves I and II, about 80% of subjects reported having had no sexual partners. In Wave III, though, nearly 70% of the sample reported one to three partners.

The direct AED measure's correlations with the reproductive variables are similar but slightly smaller, likely because the factor variable is a more comprehensive measure. It is particularly worth noting that scoring highly on an AED factor variable at one wave is correlated with the reproductive behaviors at the following wave. According to life history theory, discounting of the future leads one to accelerate his or her life history in an effort to optimize reproduction and pass on genetic material. This means that people who expect to die young will have sex often and with numerous partners, and will reproduce at earlier ages than peers who do not discount the future. This is borne out in the correlations, supporting the notion that the factor variables do measure AED.

RYDS

The latent AED variables in the RYDS dataset are estimated using the same methods I used with the Add Health data. To measure AED in Mplus, I execute a second-order factor analysis, wherein the components of the AED factor variable are themselves factor variables. I will not repeat the exhaustive description of this process that is detailed in the Add Health section above. Here, I dive straight into the description of the second-order factor analysis. The variables used in the model are described in the beginning of this chapter and in Appendices A and B.

Second-order factor analysis.

Table 4.5 provides the factor loadings and fit statistics for the measurement models in waves 2 through 8 of the RYDS sample. The models are narrowed in the same way as the Add Health models, as described above.

The loadings for each variable are similar across the seven waves and also similar to the loadings from the Add Health models. As in the Add Health models, low self-esteem consistently has the largest loadings, ranging from .83 to .89 in the RYDS data. Depression, low attachment to parents, and low school connection also have fairly high loadings at each wave, in the .50 to .70 range. Parent unemployment has loadings greater than .30 for waves 3, 5, and 8 only; this variable does not load in the Add Health data.

Like the loadings, the fit statistics for the RYDS models are similar to those for the Add Health models. The TLI values range from .92 to .94, indicating that the models fit the data acceptably well. The RMSEA of .09 at wave 7 indicates a mediocre-to-poor fit, but the other waves are adequate, with RMSEAs of .07 or .08.

Differences by sex.

As in the Add Health data, I also estimate the second-order factor analyses by sex, to determine whether different factors are crucial in the measurement of future discounting for the two sexes.

Table 4.6 presents the final model loadings and fit statistics for waves 2 through 8, by sex. The biggest difference between males and females is that parent unemployment is an important component of AED for females but not for males, loading for five out of the seven female-only models but only three male-only models.

The model fit statistics for the male models are slightly better than for the female models. The fit statistics for the female models are less indicative of a good model fit, with TLI values ranging from .89 to .92 and RMSEAs ranging from .08 to .11. The poorer fit of the female models relative to the male models may be attributed to the difference in sample size. Because RYDS oversampled at-risk youth, the sample is 72% male ($N = 579$) and 28% female ($N = 225$). A larger female sample might improve model fit.

Evaluation of reliability and validity.

As with the Add Health variables and process, given the theoretical foundation supporting the relationships between the latent measure and the observed variables in the factor analysis, I am confident that this process measures future discounting, as intended. To further support this claim, I evaluate the psychometrics of the created factor variables.

To begin evaluating the factors, I calculate the Cronbach's alpha using the variables created by the first-order factor analysis. The α values range from .73 (wave 5) to .79 (waves 4 and 7). Being larger than .70, these values support reliability of the AED measures (Cortina, 1993).

The first six rows in Table 4.7 provide correlations for the AED factors across waves. The correlations are fairly strong, ranging from .46 (waves 2 and 8) to .76 (waves 6 and 7). This demonstrates that the factors measure the same concept over time.

To evaluate the validity of the measure using my guiding framework of life history theory, I calculate the polychoric correlations for the AED factor variables and the measures of reproductive behavior.²⁰ The reproductive behavior variables measure the number of sexual partners a subject reports having since the last interview and whether the subject has ever (up to that wave) been pregnant (if female) or impregnated someone (if male). The RYDS correlations between AED and number of sexual partners are all fairly low, ranging from 0 to .11. The correlations between AED and pregnancy are larger, ranging from .10 to .26. There's no clear pattern; pregnancy at all waves correlates more strongly with AED measured at wave 4 than AED at any other waves. These correlations are something of a mixed bag; the Add Health relationships are stronger and more suggestive.

Summary

In this chapter, I meet the first study objective by using two secondary datasets to create latent measures of future discounting. Including identical or similar measures in both the Add Health and RYDS models, I find that many of the same variables load strongly to build latent measures of AED in both samples. Specifically, depression, low self-esteem, low attachment to parents, and low connection to school load onto the AED factor variables at each wave in both the Add Health and RYDS datasets.

²⁰ I do not show correlations between AED and delinquent behaviors for RYDS as I do for Add Health because there is no direct AED measure in RYDS to compare with the factor variables. With the RYDS measurement, then, it only makes sense to evaluate predictive validity using the theoretical framework, not by determining whether the factor variables predict dependent variables similarly to direct AED measures (as in the Add Health measurement evaluation).

However, there are also divergences between the two data sources. In the Add Health data only, poor academic performance, receipt of public assistance, and living in an unsafe neighborhood (Wave I only) also load onto the latent AED constructs. These variables do not load in the RYDS data, but the measure of parental unemployment does (albeit in waves 3, 5, and 8 only). These findings suggest dissimilarities in the measurement of AED in different samples. The Add Health sample is nationally representative, while the RYDS oversampled males and youths at risk of delinquency. The RYDS sample is therefore more homogeneous in several ways; this may account for the non-loading of public assistance receipt and living in an unsafe neighborhood. The discrepancy in poor academic performance may result from measurement differences – in the Add Health models I measure poor academic performance by factor analyzing self-reported grades in the four core subjects; in RYDS, I use a measure of performance on the math portion of the California Achievement Test. It seems the math-specific measure, though it has performed well in other RYDS analyses (Thornberry et al., 2003), does not impact AED as strongly as a measure that encompasses performance in several different subjects. Future research should seek to further identify differences in AED measurement in various samples, to determine whether and how AED varies.

After creating the latent constructs using second-order factor analysis, I evaluate the reliability and validity of the measures to confirm that they measure AED as intended. The use of several different methods (i.e., computation of Cronbach's alpha values and correlations with direct AED measures as well as delinquent and reproductive behaviors) bolstered the validity of the AED factor variables in the Add Health and RYDS samples.

In the next three chapters, I use the newly-created AED factor variables to explore the relationships between AED, violence, and gang membership.

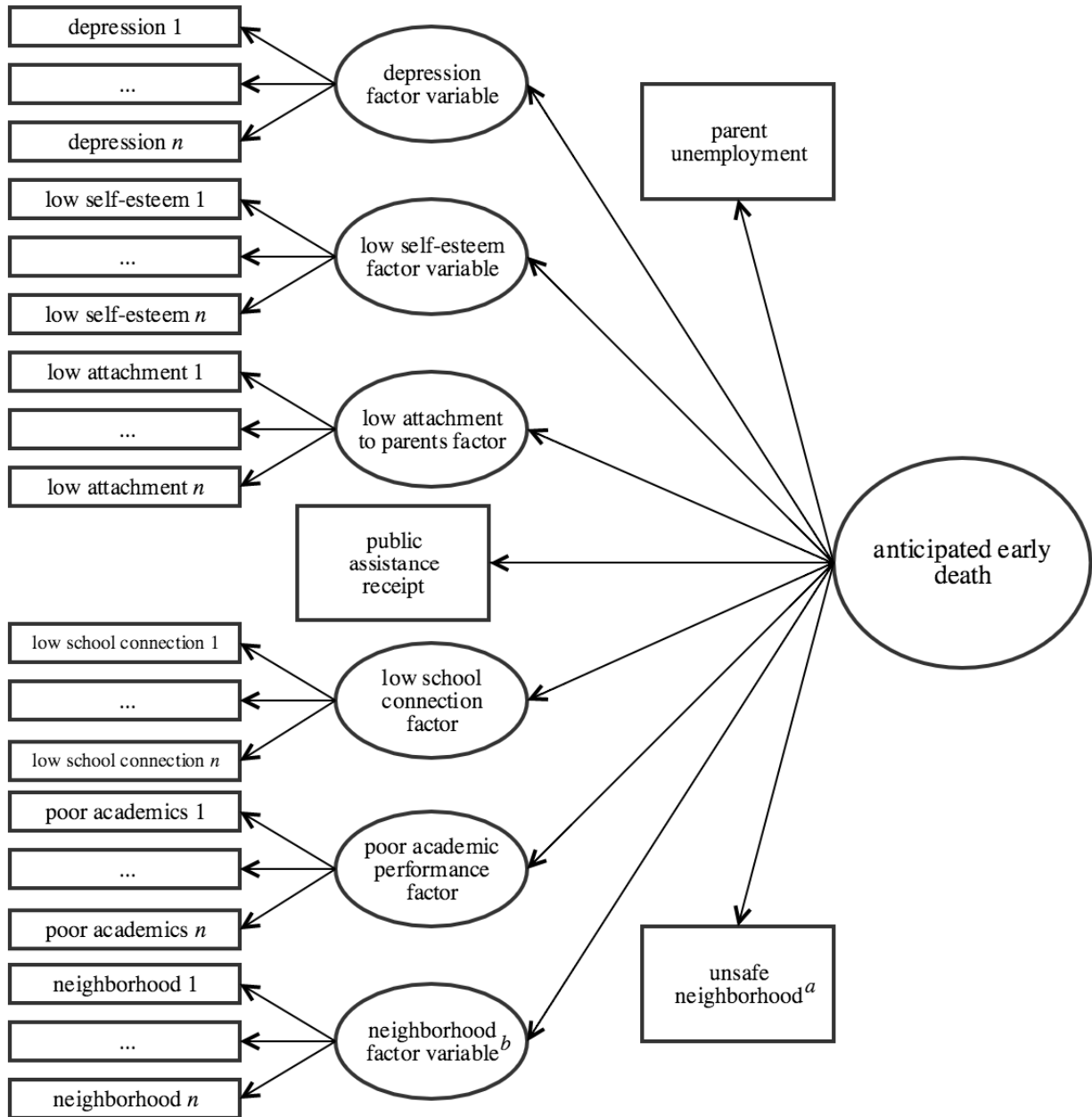

^a Measure is specific to Add Health

^b Measure is specific to RYDS

Figure 4.1. Second-Order Measurement Model

Table 4.1. Add Health Wave I AED Measurement Model (Standardized Loadings)

	Model 0		Model 1		Model 2	
	<i>b</i>	(SE)	<i>b</i>	(SE)	<i>b</i>	(SE)
Die by 35	.42	(.01)				
Depression	.71	(.01)	.69	(.01)	.69	(.01)
Low self-esteem	.78	(.01)	.79	(.01)	.80	(.01)
Low attachment to parents	.58	(.02)	.58	(.02)	.58	(.02)
Poor academic performance	.38	(.02)	.37	(.02)	.37	(.02)
Low school connection	.63	(.02)	.64	(.02)	.64	(.02)
Public assistance receipt	.28	(.03)	.39	(.01)	.39	(.01)
Parent unemployed	.16	(.04)	.16	(.04)	---	---
Unsafe neighborhood	.34	(.03)	.33	(.03)	.33	(.03)
χ^2	5194*		5002*		4866*	
TLI	.94		.94		.94	
RMSEA	.06		.07		.07	

SE = standard error; TLI = Tucker-Lewis Index; RMSEA = root mean square error approximation

Table 4.2. Add Health Waves I and II AED Measurement Models (Standardized Loadings)

	<u>Wave I</u>		<u>Wave II</u>	
	<i>b</i>	(SE)	<i>b</i>	(SE)
Depression	.69	(.01)	.68	(.01)
Low self-esteem	.80	(.01)	.76	(.02)
Low attachment to parents	.58	(.02)	.55	(.02)
Poor academic performance	.37	(.02)	.37	(.02)
Low school connection	.64	(.02)	.61	(.02)
Public assistance receipt	.39	(.01)	.39	(.01)
Unsafe neighborhood	.33	(.03)	---	---
χ^2	4866*		4783*	
TLI	.94		.94	
RMSEA	.07		.07	

SE = standard error; TLI = Tucker-Lewis Index; RMSEA = root mean square error approximation

Table 4.3. Add Health AED Measurement by Sex (Standardized Loadings)

	Wave I				Wave II -			
	Male		Female		Male		Female -	
	<i>b</i>	(SE)	<i>b</i>	(SE)	<i>b</i>	(SE)	<i>b</i>	(SE) -
Depression	.62	(.02)	.73	(.02)	.65	(.02)	.71	(.02)
Low self-esteem	.79	(.02)	.79	(.02)	.75	(.02)	.74	(.02)
Low attachment to parents	.50	(.03)	.61	(.03)	.49	(.03)	.57	(.03)
Poor academic performance	.39	(.03)	.45	(.03)	.38	(.03)	.44	(.03)
Low school connection	.68	(.02)	.63	(.02)	.62	(.03)	.62	(.02)
Public assistance receipt	.34	(.02)	.41	(.02)	.33	(.02)	.42	(.02)
Unsafe neighborhood	.33	(.05)	.35	(.04)	---	---	.30	(.04)
χ^2	1945*		2597*		1943*		2729*	
TLI	.93		.95		.94		.95	
RMSEA	.06		.07		.07		.07	

SE = standard error; TLI = Tucker-Lewis Index; RMSEA = root mean square error approximation

Table 4.4. Correlations of Add Health AED Indirect and Direct Measures with Outcome

Behaviors

	AED WI	AED WII	Die by 35 WI	Die by 35 WII	Die by 35 WIII
<i>AED</i>					
AED WII	.69				
Die by 35 WI	.34	.30			
Die by 35 WII	.29	.35	.49		
Die by 35 WIII	.21	.20	.32	.36	
<i>Delinquent behavior</i>					
Violence prevalence WI	.27	.22	.19	.18	.15
Violence prevalence WII	.19	.21	.14	.16	.12
Violence prevalence WIII	.07	.09	.13	.13	.19
<i>Sexual behavior</i>					
Number of sexual partners WI	.24	.20	.18	.19	.06
Number of sexual partners WII	.13	.18	.15	.15	.05
Number of sexual partners WIII	.07	.05	.04	.05	.06
Pregnancy WI	.29	.23	.17	.08	.15
Pregnancy WII	.27	.24	.18	.16	.14
Pregnancy WIII	.25	.25	.14	.17	.05

Table 4.5. RYDS AED Measurement Models (Standardized Loadings)

	<u>Wave 2</u>		<u>Wave 3</u>		<u>Wave 4</u>		<u>Wave 5</u>		<u>Wave 6</u>		<u>Wave 7</u>		<u>Wave 8</u>	
	<i>b</i>	(SE)	<i>b</i>	(SE)	<i>b</i>	(SE)	<i>b</i>	(SE)	<i>b</i>	(SE)	<i>b</i>	(SE)	<i>b</i>	(SE)
Depression	.62	(.03)	.62	(.03)	.61	(.03)	.62	(.03)	.55	(.03)	.56	(.03)	.60	(.03)
Low self-esteem	.89	(.03)	.88	(.03)	.84	(.03)	.83	(.03)	.89	(.03)	.84	(.03)	.83	(.03)
Low attachment to parents	.56	(.03)	.56	(.04)	.57	(.03)	.58	(.04)	.51	(.04)	.57	(.03)	.52	(.03)
Low school connection	.55	(.04)	.64	(.03)	.62	(.03)	.58	(.04)	.63	(.03)	.65	(.03)	.67	(.04)
Parent unemployed	---	---	.31	(.03)	---	---	.34	(.02)	---	---	---	---	.35	(.03)
χ^2	1120*		1168*		1191*		1186*		1143*		1172*		1115*	
TLI	.92		.93		.93		.93		.93		.93		.94	
RMSEA	.07		.08		.08		.08		.08		.09		.08	

SE = standard error; TLI = Tucker-Lewis Index; RMSEA = root mean square error approximation.

Table 4.6. RYDS AED Measurement Models by Sex (Standardized Loadings)

<i>Male</i>	2		3		4		5		6		7		8	
	<i>b</i>	(SE)	<i>b</i>	(SE)	<i>b</i>	(SE)	<i>b</i>	(SE)	<i>b</i>	(SE)	<i>b</i>	(SE)	<i>b</i>	(SE)
Depression	.62	(.04)	.64	(.03)	.59	(.04)	.56	(.04)	.55	(.04)	.56	(.04)	.61	(.03)
Low self-esteem	.92	(.04)	.90	(.03)	.87	(.03)	.87	(.04)	.88	(.04)	.88	(.03)	.81	(.03)
Low attachment to parents	.53	(.04)	.57	(.04)	.59	(.04)	.57	(.04)	.54	(.04)	.57	(.04)	.55	(.04)
Low school connection	.62	(.04)	.63	(.04)	.69	(.03)	.63	(.04)	.68	(.04)	.69	(.04)	.71	(.04)
Parent unemployed	---	---	.31	(.03)	---	---	.31	(.03)	---	---	---	---	.34	(.03)
χ^2	775*		806*		855*		858*		810*		818*		734*	
TLI	.92		.93		.93		.93		.94		.93		.94	
RMSEA	.07		.08		.08		.08		.09		.09		.08	

<i>Female</i>	2		3		4		5		6		7		8	
	<i>b</i>	(SE)	<i>b</i>	(SE)	<i>b</i>	(SE)	<i>b</i>	(SE)	<i>b</i>	(SE)	<i>b</i>	(SE)	<i>b</i>	(SE)
Depression	.65	(.05)	.61	(.05)	.69	(.06)	.78	(.05)	.55	(.06)	.56	(.05)	.57	(.06)
Low self-esteem	.78	(.06)	.85	(.06)	.73	(.05)	.72	(.05)	.89	(.07)	.76	(.06)	.85	(.06)
Low attachment to parents	.64	(.06)	.53	(.06)	.53	(.06)	.59	(.06)	.42	(.07)	.58	(.07)	.46	(.06)
Low school connection	.44	(.08)	.71	(.05)	.52	(.06)	.54	(.06)	.57	(.06)	.64	(.05)	.64	(.06)
Parent unemployed	---	---	.31	(.05)	.31	(.05)	.44	(.05)	.35	(.05)	.33	(.04)	---	---
χ^2	261*		305*		313*		277*		278*		310*		320*	
TLI	.90		.91		.89		.92		.91		.90		.92	
RMSEA	.08		.09		.10		.10		.10		.11		.10	

SE = standard error; TLI = Tucker-Lewis Index; RMSEA = root mean square error approximation

* $p \leq .05$

Table 4.7. Correlations of RYDS AED Indirect Measures with Sexual Behaviors

	AED 2	AED 3	AED 4	AED 5	AED 6	AED 7	AED 8
AED 3	.74						
AED 4	.68	.74					
AED 5	.59	.65	.73				
AED 6	.54	.59	.69	.71			
AED 7	.55	.59	.67	.68	.76		
AED 8	.46	.54	.60	.62	.67	.72	
<i>Sexual behavior</i>							
Number of sexual partners 6	.10	.05	.07	.04	.03	.00	.03
Number of sexual partners 7	.11	.09	.10	.10	.06	.07	.03
Number of sexual partners 8	.06	.02	.03	.06	.03	.05	.03
Number of sexual partners 9	.11	.05	.07	.07	.06	.08	.05
Pregnancy 5	.14	.11	.21	.14	.15	.12	.15
Pregnancy 6	.17	.17	.24	.17	.20	.18	.20
Pregnancy 7	.19	.20	.26	.17	.18	.18	.16
Pregnancy 8	.18	.17	.22	.15	.15	.17	.12
Pregnancy 9	.16	.13	.20	.10	.11	.13	.11

CHAPTER 5

AED and Violent Behavior

Having created valid and reliable AED proxy measures in both the Add Health and RYDS datasets in Chapter 4, I can now examine the effects of the AED latent measures on risk-taking behaviors using structural equation modeling.

Figure 2.1, presented in Chapter 2's discussion of the theoretical model, illustrates the structural models estimated in this chapter and the next, for both the Add Health and the RYDS data. Here, I examine the effects of AED on low self-control (path A), low self-control on risk-taking behaviors (path B), AED on risk-taking behaviors directly (path C), and AED on risk-taking behaviors indirectly, through low self-control (indirect path A-B). Risk-taking behaviors are measured at $t+1$, the wave following the one at which AED is measured (t).

In this chapter, I first study the way in which AED affects risk-taking behavior in the Add Health data, as operationalized by self-reported prevalence of violent offending. I then examine the influence of AED on self-reported prevalence and variety of violent offending in the RYDS data. These relationships are further examined by estimating the models separately for male and female participants.

Add Health

Violence prevalence.

I first apply the model to an Add Health variable measuring violence prevalence, coded 1 if a subject reported engaging in any of the five behaviors (e.g., fighting, robbery, rape) listed in the variable coding table in Appendix A.

The results of the SEM are displayed in Table 5.1. The top third of the table presents standardized coefficients, standard errors, and fit statistics from the full-sample SEMs. In the left-hand column of results, where AED is measured at Wave I and violence is measured at Wave II, the strongest path measures the relationship between AED and low self-control ($b = .85, p \leq .001$). This indicates that, although fatalism and low self-control are distinct concepts (LaGrange & Silverman, 1999; Mishra & Lalumière, 2011), they are strongly related. The significant coefficient for the relationship between low self-control and violence ($b = .30, p \leq .001$), indicates that individuals with low self-control have a higher likelihood of engaging in violence, a relationship backed by much scientific support (Gottfredson & Hirschi, 1990).

Path C, the direct path from AED to violence, has a nonsignificant, near-zero standardized coefficient. However, path A-B, measuring the indirect relationship of AED on violence via low self-control, is highly significant ($b = .26, p \leq .001$), suggesting that low self-control mediates the relationship between AED and violence prevalence. The total effect of AED on violence in Wave I is $.24 (p \leq .001)$. Thus, AED strongly impacts violence, but this relationship is mediated by low self-control.

The fit statistics for this model do not suggest an excellent fit. The χ^2 is statistically significant, indicating that the model is not a perfect fit for the data. The TLI (.91) and the RMSEA (.08) fall into their acceptable ranges. Altogether, these values suggest an acceptable fit for the Add Health data.

Some of the relationships in Wave II (shown in the rightmost column in the top third of Table 5.1) are similar. As in Wave I, the strongest relationship is the one between AED and low self-control, with a standardized coefficient of $.89 (p \leq .001)$. The next strongest relationship is between low self-control and violence ($b = .52, p \leq .001$). The most noticeable difference

between the two waves is that the relationship between AED and violence in the Wave II model is negative and significant ($b = -.35, p \leq .01$), a finding suggesting that those with higher levels of AED are less likely to engage in violence. This result is likely explained by the gap between Waves II and III. Wave I began in 1994; Wave II followed one year later, when most respondents were still teenagers. Wave III occurred in 2001 and 2002, five years after Wave II. By Wave III, subjects ranged in age from 18 to 27, with a mean age of 21. It is likely that in the intervening years between Waves II and III, the subjects age out of violent behavior. Indeed, by Wave III just 14% of the Add Health sample engaged in any violent behavior, compared to 42% at Wave I and 30% at Wave II. In a study of adolescence and the dramatic changes that occur during that period in one's life, a data source with more waves of data, closer together in time, is necessary to confidently draw conclusions.

Despite the negative direct effect, the total effect of AED on violence is positive ($b = .12, p \leq .001$). This results from the positive and highly significant indirect effect of AED on violence via low self-control ($b = .46, p \leq .001$). This is also the case in the Wave I model, providing evidence to support Gottfredson's and Hirschi's (1990) claim that self-control is a stable personality trait. In contrast, the model results (i.e., the change in the strength and significance of AED as a predictor of violence from Wave I to Wave II) suggest that AED is a variable factor that changes over time.

Differences by sex.

Table 5.1 also illustrates these relationships in the Add Health data by sex. The standardized coefficients for path A, representing the relationship between AED and low self-control, are high in all four models, ranging from .84 (Wave I males) to .90 (Wave II males). The only other relationship significant in all four of the sex-separated models is the one measuring

the total effects of AED on violence. These coefficients range from .15 (Wave II males) to .33 (Wave I females), with all coefficients reaching significance at a level of $p \leq .001$. With the exception of the Wave II males-only model, though, none of the direct or indirect effects of AED and low self-control on violence are statistically significant. In the Wave II model for male subjects, the relationships between low self-control and violence ($b = .40$) and the indirect effect of AED on violence via low self-control ($b = .37$) both reach significance at $p \leq .05$.

These models indicate that the relationships between AED, low self-control, and violence are largely similar for both males and females at Wave I in the Add Health data. To determine whether the coefficients for one sex significantly differ from the other, I calculate z scores using the formula for comparison of coefficients recommended by (Paternoster, Brame, Mazerolle, & Piquero, 1998, p. 862):

$$z = \frac{b_1 + b_2}{\sqrt{SEb_1^2 + SEb_2^2}}$$

Table 5.2 contains the z scores for pairwise comparisons of the coefficients for the sex-separated models. Only one z score lies outside the -1.96 to 1.96 bounds, allowing for rejection of the null hypothesis of no difference between the coefficients. The coefficients for the total effects of Wave I AED on Wave II violence differ significantly ($z = -2.40$), indicating that this relationship is stronger for females. This unexpected finding runs counter to my hypothesis that AED would predict violence more strongly for males.

The model fit statistics for the sex-separated models are slightly better than those for the full-sample model. The TLI and RMSEA values fall within their acceptable ranges.

AED measurement revisited.

In keeping with my guiding theoretical framework of life history theory, I expected to find evidence of significant relationships between AED and risk-taking behaviors. In the context of evolutionary biology, life history theory posits that a truncated life expectancy will correspond to an increase in risky behaviors to facilitate mate selection. To use life history theory to further validate the AED proxy measures as the project progresses, I estimate structural models that include a measure of reproductive behavior. According to life history theory, AED should significantly predict reproductive factors such as one's number of sexual partners, pregnancy, and precocious sexual activity. Here, I employ categorical variables of self-reported number of sexual partners within the prior 12 months and pregnancy (ever), measured two waves (i.e., six years) after AED. In the wave between AED and the sexual behavior, I include the measure of violence prevalence. Due to a few outliers reporting as many as 50 sexual partners, the variable measuring number of sexual partners is a categorical measure divided into three groups: zero partners, one to three partners, or four or more partners. At Wave III, about 22% of the sample reported no sexual partners within the last 12 months, 69% reported one to three partners, and 9% reported more than three partners. By Wave III, almost a third of the Add Health sample ($N = 1,062$, 31%) had experienced at least one pregnancy.

Table 5.3 shows the results of three-wave structural models as illustrated in Figure 2.1. The model on the left measures the effects of AED and low self-control at Wave I on violence at Wave II and the number of sexual partners reported at Wave III. Path E, measuring the direct effect of AED on number of partners, is nonsignificant. However, due to two significant indirect effects between AED and number of partners (AED to low self-control to violence, and AED to low self-control), the total effect of AED on number of partners is significant ($b = .09, p \leq .001$).

The components of the model concerned only with AED, self-control, and violence are exactly the same as the results for the two-wave model in Table 5.1.

The model on the right replaces number of partners with pregnancy at Wave III. Path E, measuring the direct relationship between AED and pregnancy, is strong and significant ($b = .74$, $p \leq .001$), but this direct effect is partially negated by self-control's negative effect on pregnancy (indirect path A-D). Even so, the total effect of AED on pregnancy is positive and highly significant ($b = .32$, $p \leq .001$).

These results indicate that AED strongly affects pregnancy and, to a lesser extent, one's number of sexual partners, as expected. According to life history theory, AED should affect both of these reproductive variables – pregnancy, because a truncated life expectancy should encourage one to pass on one's genes, and number of sexual partners because it improves one's chances of reproductive success (i.e., pregnancy). These findings are also in line with the zero-order correlations presented in Chapter 4, when I originally assessed the validity of the AED proxy measures. In particular, as Table 4.4 shows, the strength of the associations between pregnancy and both my latent measure of AED as well as Add Health's direct AED variable, both measured at Wave I, remain similarly strong when looking at pregnancy at Waves I, II, and III. Within the life history theory framework, these relationships add further support to the validity of the latent AED measure.

RYDS

In Chapter 4 I created the latent measures of AED in the Add Health and RYDS datasets. Thus far in Chapter 5, I have studied the relationships between AED, self-control, and violence in the Add Health data, finding that self-control and AED increase the likelihood of violent behavior, with low self-control mediating the effect of AED on violence prevalence. I now

replicate and expand these analyses with a deeper dive into the RYDS data, to further evaluate the validity of the latent AED measures and to measure the effects of AED on violent behavior in the RYDS data.

There are several benefits to using the RYDS data to explore the relationship between AED and violent behavior. The RYDS used semiannual interviews to follow youth throughout their teen years, resulting in an extraordinarily rich dataset, particularly useful for examining changes over short time periods. The fact that RYDS focuses on delinquency, administering a comprehensive battery of questions about violent behavior, makes it well-suited for my purposes. To further my investigation of the associations between AED, self-control, and violent offending, I apply the model illustrated in Figure 2.1 to waves 2 through 9 of the RYDS data, predicting prevalence and variety of violent behavior.

Violence prevalence.

Table 5.4 displays the results of the full-sample RYDS models predicting violence prevalence, i.e., whether a participant reported engaging in any of the six violent behaviors: assault, aggravated assault, robbery, gang fighting, throwing objects at people, rape/attempted rape. As in Table 5.1, the numbers across the tops of the columns represent the wave at which AED is measured (t), with the dependent variable measured at the following wave ($t+1$). In the Add Health models, low self-control is measured at the same wave as AED. In the RYDS models, however, low self-control is measured only once (at wave 10), and I use that variable in all of the models under Gottfredson's and Hirschi's (1990) assumption that self-control is a static personality characteristic.

The relationship between AED and low self-control (path A) remains similarly strong across all waves, ranging from .32 (wave 4) to .39 (waves 7 and 8), with all path A coefficients

significant at $p \leq .001$. The direct effect of AED on violence prevalence (path C) declines over time, from .30 ($p \leq .001$) at wave 2 to .06 (ns) at wave 8. The total effect of AED on violence prevalence also declines over time, starting at .33 ($p \leq .001$) when AED is measured at wave 2 and falling to .16 ($p \leq .05$) when AED is measured at wave 8. These results indicate that AED has a weaker impact on engagement in violence by the late teen years. The total effects of AED on violence remain statistically significant across the waves, though.

Interestingly, the effect of low self-control on violence (path B) appears to grow over time, from .11 ($p \leq .05$) at wave 2 to .27 ($p \leq .001$) at wave 8. This suggests that as adolescents reach their late teens, the power of low self-control intensifies while AED's influence on violence wanes. Perhaps younger adolescents engage in violence more purposefully (i.e., less impulsively) owing to a need to establish status when entering the teen scene, or as a result of socialization by older teenagers.²¹ By the later teenaged years, though, self-control is the stronger predictor, perhaps because those with higher AED have been socialized into the culture and are more comfortable using violence as an impulsive reaction.

The model fit statistics are similar for all of the seven models displayed in Table 5.4. The TLI values are acceptable for all models, ranging from .92 to .94. All RMSEA values also fall within the acceptable range.

Differences by sex.

As in the Add Health data, I also estimate the SEMs by sex, to determine whether the effects of AED and self-control on violent engagement vary by sex. According to life history theory, males who have a short time horizon take risks in order to improve their chances of

²¹ For example, Canada's (1995) memoir of street violence describes the process by which the 17- to 19-year-olds at the top of the neighborhood's pecking order make young boys fight each other, then praise their displays and give them tips on how to fight.

reproductive success. Although females may also expect to die young, they are more likely to respond by becoming sexually active earlier and more often; violence is not a typical consequence of AED for females. Because the RYDS sample is mostly male by design, the full-sample model results are similar to the results for the male-only models. The principal utility of estimating the models by sex, then, is to more precisely model the relationships for the female participants.

Table 5.5 displays the results of the sex-separated structural models predicting violence prevalence. I calculate z scores to allow for comparison of the male-model coefficients to the female-model coefficients (Appendix C). In the wave 2 model, the relationship between AED and violence is significantly larger for females ($b = .47, p \leq .001$) than it is for males ($b = .26, p \leq .001; z = -2.04$). In the same model, the total effect of AED on violence is, unsurprisingly, also significantly larger for females ($b = .54, p \leq .001$) than males ($b = .28, p \leq .001; z = -2.76$). The same pattern occurs at wave 7 – the direct and total effects of AED on violent engagement are significantly larger for females than males. These are the only relationships that significantly differ by sex.

These findings obviously do not support the hypothesis that higher levels of AED will influence violent behavior for males but not females. Instead, it appears that AED affects violence for females and males both, but at around ages 14.5 and 17, AED is a significantly stronger predictor of violence six months later for females, compared to males. The reason for this relationship is unclear. A great deal of research has found that males are more likely to engage in violent behavior than females (Ellis et al., 2012), but I have found no support of the opposite in the literature. This surprising difference between the sexes may result from the relative lack of variance in violence engagement among the males in the sample, compared to the -

females. At wave 3, 171 of the RYDS males (30%) report engaging in violence. Of these individuals, 10% have low AED (i.e., their AED values are less than the variable's mean minus one standard deviation). Nearly three-quarters of the males who report violence at wave 3 are within one standard deviation (plus or minus) of the AED mean. The remaining 16% have high AED values, greater than the variable mean plus one standard deviation. In contrast, just under one quarter of female respondents report engaging in violence at wave 3, and of those individuals, 28% have high AED values. Just one violent female (2%) has low AED, compared to 17 (10%) violent males. It appears that females must reach a higher threshold of AED before they will become violent, whereas males with low, average, or high AED will engage in violence.

The model fit statistics for the male models are similar to those for the full-sample models, but the fit statistics for the female models are worse than for the full-sample models. The RMSEA values for the female models are .09 or .10 for six of the seven models. Many consider an RMSEA greater than .08 indicative of a poor model fit (Schumacker & Lomax, 2010). The TLI value falls to .89, below the .90 threshold of acceptability, in waves 4 and 7. Taken together, these fit statistics indicate that the model is a poorer fit for the females relative to the males.

Violence variety.

Table 5.6 presents the results of structural equation models for the full RYDS sample with the endogenous variable measuring the variety of violent acts in which one reported engaging. This variable measures the number of different *types* of violent acts a subject reports engaging in. For example, a subject who reports committing two robberies and five assaults is coded 2, receiving one point for each type of violent crime (here, robbery and assault). Values

for the measure of violence variety range from 0 to 5. The variable's mean of 0.29 across all waves indicates that most subjects engage in zero to one types of violent acts per wave.

These models follow a similar pattern as the models for violence prevalence (in Table 5.4). All path B coefficients are significant at the level of at least $p \leq .01$, indicating a strong relationship between low self-control and the number of various types of violence in which one engages. These coefficients increase over time, suggesting that self-control has a stronger influence on violence variety in later adolescence. This may be because youths are more comfortable engaging in violence impulsively when they are in their late teens and have had time to learn the culture and experiment with various delinquent acts. In contrast to the self-control findings, the path C values, representing the direct effects of AED on violence variety, start higher and then fall in both size and significance over time, from .26 ($p \leq .001$) at wave 2 to .12 ($p \leq .05$) at wave 5, with the remainder of the waves showing no significant path C relationship. This indicates that AED directly affects one's variety of violent behavior in early- to mid-adolescence but not in later years. However, the indirect path A-B is statistically significant at all waves, as is the total effect of AED on violence variety. Directly, indirectly, or both, AED impacts the variety of one's violent offending throughout adolescence.

Differences by sex.

Table 5.7 presents the results of the sex-separated SEMs predicting violence variety. The z scores (Appendix C) show that the two sexes differ in the total effect of AED at wave 2 on violence variety at wave 3 – this effect is significantly stronger for females. Further, the sexes differ significantly in the relationship between AED and violence variety in the models for waves 6 and 7. At wave 6, the direct and total effects of AED are significantly larger for male subjects. At wave 7, the reverse is true – the path C coefficient and AED's total effect are significantly

larger for female participants. Again, the stronger relationship between AED and violence for females compared to males is counterintuitive and unsupported in the literature. A look at the cross-tabulations by low, average, and high levels of AED supports the notion that this is because females require a higher level of AED to become violent, particularly when this entails engaging in multiple different types of violence.²² In contrast, even male subjects with lower-than-average AED at wave 2 still commit up to four (of five) different violent acts at wave 3.

AED measurement revisited.

Using the context of life history theory, I now add measures of reproductive behaviors to the RYDS models to further evaluate the reliability of the AED latent variables. According to life history theory, a shortened life expectancy affects sexual behavior as one prioritizes reproduction above other competing goals, namely survival. Here, I employ categorical variables of pregnancy and self-reported number of sexual partners, measured one year after AED. In the wave between AED and the reproductive behavior, I include a measure of violent behavior to test for mediating effects.

Due to a few outliers reporting as many as 90 sexual partners, the variables measuring number of sexual partners are categorical measures divided into three groups: zero sexual partners since the last interview, one to three partners, or four or more partners. The RYDS interviews include this item beginning in wave 6, when about 47% report no sexual partners, 45% report one to three partners, and 8% report more than three partners. By wave 9, 36% report no sexual partners since the last interview, 58% report one to three partners, and 6% report four or more partners. The pregnancy variable measures whether the respondent has ever become pregnant or gotten someone pregnant, up until the wave at which the question is asked. In

²² The cross-tabulations are not presented here but are available upon request.

wave 5, when the variable is first measured for both sexes, 12% of the sample have been pregnant or impregnated someone. By wave 9, almost a third of the RYDS sample ($N = 226$, 28%) have experienced at least one pregnancy.

Table 5.8 shows the results of the three-wave structural models as illustrated in Figure 2.1. The models include AED factor variables at wave t (denoted by the number at the top of the column), violence prevalence at wave $t+1$, and the number of sexual partners reported at wave $t+2$. The first column of results, then, measures AED at wave 4, violence at wave 5, and sexual partners at wave 6 (the first wave at which the question is asked). Path E, measuring the direct effect of AED on number of partners, is nonsignificant in all of the models. However, the total effect of AED on number of partners is significant in the first two results columns, when number of partners is measured at around ages 16.5 to 17. This is due to significant indirect effects between AED and number of partners – paths A-B-F (AED to low self-control to violence to partners), A-D (AED to low self-control to partners), and C-F (AED to violence to partners) from ages 15.5 to 16.5 and path A-B-F from ages 16 to 17. AED does not significantly predict number of partners when the endogenous variable is measured at ages 17.5 to 18, in waves 8 and 9.

Table 5.9 replaces number of partners with pregnancy as the endogenous variable. This table includes one more column of results than Table 5.8 because measurement of pregnancy for both sexes begins in wave 5 (one wave earlier than the item about number of sexual partners).

Path E is significant when AED is measured at waves 4 ($b = .20, p \leq .001$) and 5 ($b = .15, p \leq .01$), but the other three models do not show a significant direct effect of AED on pregnancy. Due to significant indirect effects, though, the total effects of AED on pregnancy are statistically significant in all models. In particular, the indirect effect of AED on pregnancy via both low self-

control and violence (indirect path A-B-F) is significant ($p \leq .05$) at all waves. High levels of AED correspond to both low self-control and violence, which are associated with pregnancy in turn.

AED measured in mid-adolescence significantly predicts number of sexual partners at ages 16 to 17. AED more consistently predicts pregnancy; AED bears a significant total effect on pregnancy in the RYDS sample throughout adolescence, including a significant direct effect at waves 4 and 5 (affecting pregnancy at ages 15.5 to 16). According to life history theory, AED should influence both of these reproductive variables – pregnancy, because a short life expectancy should encourage one to pass on one's genes, and number of sexual partners because it improves one's chances of reproductive success (i.e., pregnancy). These findings are also in accordance with the correlations presented in Chapter 4, when I first judged the validity of the AED latent measures. In particular, as Table 4.7 shows, the strength of the associations between pregnancy and the latent AED measure are somewhat stronger when measuring AED at earlier waves, with AED_4 showing the strongest correlations with all pregnancy variables. Interpreted through a lens of life history theory, these relationships add further support to the validity of the latent AED measure. An ideal finding would show AED predicting both number of partners and pregnancy at all waves, though, so it's likely that the latent measures of AED are imperfect. A latent measure of AED should include a number of additional factors linked to AED, for example, exposure to violence and community mortality rate, among other factors discussed in Chapter 1's review of the literature. Given the limitations and restrictions of the datasets and design used in the dissertation, the latent measures of AED perform well and find sufficient support in life history theory.

Summary

This chapter examines the effects of the latent measures of anticipated early death on violent behavior in both the Add Health and RYDS samples. The takeaway finding is that, generally speaking, AED, low self-control, and AED via low self-control substantially influence violent behavior. Low self-control significantly predicts violence in all of the full-sample models presented in this chapter. The indirect effect of AED on violence via low self-control is also significant in all full-sample models here. Accordingly, AED has a significant total effect on violence in all full-sample models.

The only path without a statistically significant coefficient in all of the full-sample Add Health and RYDS models presented in this chapter, then, is the direct effect of AED on violence. In the Add Health data, AED at around age 16 has a negative and significant relationship with violence prevalence five years later. This unexpected finding may be due to those who anticipate an early death behaving more cautiously in order to improve their life chances – by Wave III, respondents are adults, ranging in age from 18 to 27. During the five years between Waves II and III, Add Health participants seem to have matured enough to behave more rationally, exercising caution in response to AED. In the RYDS data, AED at ages 14.5 to 15.5 has a significant positive relationship with violence prevalence and variety six months later. By later adolescence, though, AED no longer predicts violent behavior, and low self-control holds more sway.

The models, particularly those for females only, do not fit perfectly. It's probable that omitted variables play a strong role in these relationships, in addition to the latent measures included in the structural models. For example, delinquency of one's peers is a strong known predictor of one's own delinquency (Kissner & Pyrooz, 2009; Pratt & Cullen, 2000; Thornberry et al., 2003). Such a measure is not included here for two reasons. First, it does not exist in the

Add Health data, and one of my primary goals in creating the AED proxy measures and estimating the structural models is resemblance between the two datasets. The other reason I forego use of peer delinquency measures is because I found no evidence of a link between AED and peer delinquency in the literature. Although one might exist, it's more likely that a fatalistic attitude is influenced by the victimization experienced by one's peers, rather than peers' offending (although the two may be closely related).

The advantage to using simple models, as I've done here, is comparability between the Add Health and RYDS samples. This is crucial, given my goal of creating latent measures of AED in two separate data sources. The drawback to the simplicity of the models is that other important factors are omitted from the analysis. Given the lack of research regarding peer effects on AED, future work should probe this potential relationship, especially with regard to risk-taking behaviors and violence in particular.

Exploration of the effects of peer behavior on AED, while regrettably overlooked in the literature, lies outside the scope of the dissertation. However, I devote the next chapter to something similar: the effects of AED on gang activity.

Table 5.1. Add Health Structural Models of AED and Violence Prevalence (Standardized Coefficients)

		I		II	
		<i>b</i>	(SE)	<i>b</i>	(SE)
Path A	(AED _{<i>t</i>} → LSC _{<i>t</i>})	.85*	(.01)	.89*	(.01)
Path B	(LSC _{<i>t</i>} → violence _{<i>t+1</i>})	.30*	(.07)	.52*	(.13)
Path C	(AED _{<i>t</i>} → violence _{<i>t+1</i>})	-.02	(.07)	-.35*	(.13)
Indirect A-B	(AED _{<i>t</i>} → LSC _{<i>t</i>} → violence _{<i>t+1</i>})	.26*	(.06)	.46*	(.12)
<i>AED total effect</i>		.24*	(.02)	.12*	(.03)
χ^2		8374*		8684*	
TLI		.91		.91	
RMSEA		.08		.08	
<hr/>					
<i>Male</i>		I		II	
		<i>b</i>	(SE)	<i>b</i>	(SE)
Path A	(AED _{<i>t</i>} → LSC _{<i>t</i>})	.84*	(.02)	.90*	(.02)
Path B	(LSC _{<i>t</i>} → violence _{<i>t+1</i>})	.20	(.10)	.40*	(.20)
Path C	(AED _{<i>t</i>} → violence _{<i>t+1</i>})	.04	(.11)	-.22	(.20)
Indirect A-B	(AED _{<i>t</i>} → LSC _{<i>t</i>} → violence _{<i>t+1</i>})	.17	(.09)	.37*	(.18)
<i>AED total effect</i>		.21*	(.04)	.15*	(.04)
χ^2		3140*		3349*	
TLI		.92		.91	
RMSEA		.07		.08	
<hr/>					
<i>Female</i>		I		II	
		<i>b</i>	(SE)	<i>b</i>	(SE)
Path A	(AED _{<i>t</i>} → LSC _{<i>t</i>})	.88*	(.02)	.89*	(.02)
Path B	(LSC _{<i>t</i>} → violence _{<i>t+1</i>})	.19	(.12)	.09	(.22)
Path C	(AED _{<i>t</i>} → violence _{<i>t+1</i>})	.16	(.13)	.18	(.22)
Indirect A-B	(AED _{<i>t</i>} → LSC _{<i>t</i>} → violence _{<i>t+1</i>})	.17	(.11)	.08	(.19)
<i>AED total effect</i>		.33*	(.03)	.26*	(.04)
χ^2		3827*		4321*	
TLI		.92		.92	
RMSEA		.07		.08	

SE = standard error; TLI = Tucker-Lewis Index; RMSEA = root mean square error approximation

* $p \leq .05$

Table 5.2. Comparisons of Add Health Male and Female Structural Parameters for Violence Prevalence (z scores)

	Wave I	Wave II
Path A	-1.41	0.35
Path B	0.06	1.04
Path C	-0.70	-1.35
Indirect A-B	0.00	1.11
AED total effect	-2.40*	-1.94

Note: Bold type indicates z scores that are less than -1.96 or greater than 1.96, allowing for rejection of the null hypothesis of no difference between the male-only coefficients and the female-only coefficients.

Table 5.3. Add Health Three-Wave Structural Models of AED, Violence, and Reproductive Behavior (Standardized Coefficients)

	Number of Partners		Pregnancy	
	<i>b</i>	(SE)	<i>b</i>	(SE)
Path A (AED _{<i>t</i>} → LSC _{<i>t</i>})	.85*	(.01)	.85*	(.01)
Path B (LSC _{<i>t</i>} → violence _{<i>t+1</i>})	.30*	(.07)	.30*	(.07)
Path C (AED _{<i>t</i>} → violence _{<i>t+1</i>})	-.02	(.07)	-.02	(.07)
Path D (LSC _{<i>t</i>} → reproduction _{<i>t+2</i>})	.18*	(.07)	-.54*	(.09)
Path E (AED _{<i>t</i>} → reproduction _{<i>t+2</i>})	-.11	(.07)	.74*	(.09)
Path F (violence _{<i>t+1</i>} → reproduction _{<i>t+2</i>})	.18*	(.02)	.16*	(.03)
Indirect A-B	.26*	(.06)	.26*	(.06)
Indirect A-B-F	.05*	(.01)	.04*	(.01)
Indirect A-D	.15*	(.06)	-.46*	(.08)
Indirect C-F	.00	(.01)	.00	(.01)
<i>Total effects:</i>				
AED _{<i>t</i>} → Violence _{<i>t+1</i>}	.24*	(.02)	.24*	(.02)
<i>Total effects:</i>				
AED _{<i>t</i>} → Reproduction _{<i>t+2</i>}	.09*	(.02)	.32*	(.03)
χ^2	8518*		8593*	
TLI	.91		.91	
RMSEA	.08		.08	

SE = standard error; TLI = Tucker-Lewis Index; RMSEA = root mean square error approximation

**p* ≤ .05

Table 5.4. RYDS Structural Models of AED and Violence Prevalence (Standardized Coefficients)

	2		3		4		5		6		7		8	
	<i>b</i>	(SE)	<i>b</i>	(SE)	<i>b</i>	(SE)	<i>b</i>	(SE)	<i>b</i>	(SE)	<i>b</i>	(SE)	<i>b</i>	(SE)
Path A	.33*	(.04)	.36*	(.04)	.32*	(.04)	.37*	(.04)	.36*	(.04)	.39*	(.04)	.39*	(.04)
Path B	.11*	(.05)	.20*	(.06)	.27*	(.05)	.35*	(.06)	.22*	(.06)	.25*	(.06)	.27*	(.07)
Path C	.30*	(.06)	.17*	(.06)	.14*	(.06)	.01	(.06)	.09	(.07)	.09	(.07)	.06	(.08)
Indirect A-B	.04*	(.02)	.07*	(.02)	.09*	(.02)	.13*	(.03)	.08*	(.02)	.10*	(.03)	.10*	(.03)
<i>AED total effect</i>	.33*	(.05)	.24*	(.05)	.23*	(.06)	.14*	(.06)	.17*	(.06)	.19*	(.06)	.16*	(.07)
χ^2	1226*		1218*		1268*		1237*		1233*		1285*		1203*	
TLI	.92		.93		.93		.93		.93		.93		.94	
RMSEA	.07		.07		.08		.08		.08		.08		.08	

SE = standard error; TLI = Tucker-Lewis Index; RMSEA = root mean square error approximation

* $p \leq .05$

Table 5.5. RYDS Structural Models of AED and Violence Prevalence by Sex (Standardized Coefficients)

<i>Male</i>	2		3		4		5		6		7		8	
	<i>b</i>	(SE)	<i>b</i>	(SE)	<i>b</i>	(SE)	<i>b</i>	(SE)	<i>b</i>	(SE)	<i>b</i>	(SE)	<i>b</i>	(SE)
Path A	.35*	(.05)	.36*	(.05)	.33*	(.05)	.39*	(.05)	.39*	(.05)	.40*	(.05)	.39*	(.04)
Path B	.07	(.05)	.17*	(.07)	.25*	(.06)	.34*	(.07)	.18*	(.07)	.27*	(.07)	.28*	(.07)
Path C	.26*	(.05)	.17*	(.07)	.13	(.07)	.03	(.07)	.16*	(.08)	.02	(.07)	.03	(.09)
Indirect A-B	.02	(.05)	.06*	(.03)	.08*	(.02)	.13*	(.03)	.07*	(.03)	.11*	(.03)	.11*	(.03)
<i>AED total effect</i>	.28*	(.05)	.23*	(.06)	.21*	(.06)	.16*	(.06)	.23*	(.07)	.12*	(.06)	.14	(.08)
χ^2	830*		823*		883*		874*		842*		873*		782*	
TLI	.92		.93		.92		.93		.93		.93		.94	
RMSEA	.07		.07		.08		.08		.08		.08		.08	

<i>Female</i>	2		3		4		5		6		7		8	
	<i>b</i>	(SE)	<i>b</i>	(SE)	<i>b</i>	(SE)	<i>b</i>	(SE)	<i>b</i>	(SE)	<i>b</i>	(SE)	<i>b</i>	(SE)
Path A	.33*	(.08)	.37*	(.07)	.33*	(.07)	.38*	(.06)	.33*	(.07)	.43*	(.07)	.41*	(.07)
Path B	.20*	(.09)	.23*	(.11)	.24*	(.11)	.26*	(.11)	.29*	(.12)	.15	(.11)	.18	(.15)
Path C	.47*	(.09)	.23*	(.11)	.30*	(.11)	.03	(.12)	-.11	(.13)	.36*	(.13)	.22	(.16)
Indirect A-B	.07*	(.03)	.08*	(.04)	.08*	(.04)	.10*	(.05)	.10*	(.05)	.06	(.05)	.07	(.06)
<i>AED total effect</i>	.54*	(.08)	.31*	(.10)	.38*	(.10)	.13	(.11)	-.01	(.12)	.42*	(.11)	.29*	(.14)
χ^2	276*		305*		310*		294*		290*		322*		323*	
TLI	.90		.92		.89		.91		.90		.89		.92	
RMSEA	.08		.09		.09		.10		.09		.10		.09	

SE = standard error; TLI = Tucker-Lewis Index; RMSEA = root mean square error approximation

* $p \leq .05$

Table 5.6. RYDS Structural Models of AED and Violence Variety (Standardized Coefficients)

	2		3		4		5		6		7		8	
	<i>b</i>	(SE)	<i>b</i>	(SE)	<i>b</i>	(SE)	<i>b</i>	(SE)	<i>b</i>	(SE)	<i>b</i>	(SE)	<i>b</i>	(SE)
Path A	.33*	(.04)	.36*	(.04)	.32*	(.04)	.37*	(.04)	.36*	(.04)	.39*	(.04)	.39*	(.04)
Path B	.15*	(.05)	.23*	(.05)	.28*	(.05)	.36*	(.06)	.23*	(.06)	.25*	(.06)	.27*	(.06)
Path C	.26*	(.05)	.15*	(.06)	.12*	(.05)	-.02	(.06)	.06	(.07)	.10	(.06)	.06	(.07)
Indirect A-B	.05*	(.02)	.08*	(.02)	.09*	(.02)	.13*	(.02)	.08*	(.02)	.10*	(.02)	.11*	(.03)
<i>AED total effect</i>	.31*	(.05)	.24*	(.05)	.21*	(.05)	.11*	(.05)	.14*	(.06)	.20*	(.05)	.16*	(.06)
χ^2	1228*		1214*		1263*		1236*		1234*		1282*		1204*	
TLI	.92		.93		.93		.93		.93		.93		.94	
RMSEA	.07		.07		.08		.08		.08		.08		.08	

SE = standard error; TLI = Tucker-Lewis Index; RMSEA = root mean square error approximation

* $p \leq .05$

Table 5.7. RYDS Structural Models of AED and Violence Variety by Sex (Standardized Coefficients)

<i>Male</i>	2		3		4		5		6		7		8	
	<i>b</i>	(SE)	<i>b</i>	(SE)	<i>b</i>	(SE)	<i>b</i>	(SE)	<i>b</i>	(SE)	<i>b</i>	(SE)	<i>b</i>	(SE)
Path A	.35*	(.05)	.36*	(.05)	.33*	(.05)	.39*	(.05)	.39*	(.05)	.40*	(.05)	.39*	(.04)
Path B	.10	(.06)	.20*	(.06)	.25*	(.06)	.36*	(.07)	.18*	(.07)	.25*	(.07)	.27*	(.07)
Path C	.24*	(.06)	.17*	(.06)	.12	(.06)	-.01	(.07)	.14	(.08)	.05	(.07)	.05	(.08)
Indirect A-B	.03	(.02)	.07*	(.03)	.08*	(.02)	.14*	(.03)	.07*	(.03)	.10*	(.03)	.11*	(.03)
<i>AED total effect</i>	.28*	(.06)	.24*	(.06)	.20*	(.06)	.13*	(.06)	.20*	(.07)	.15*	(.06)	.15*	(.07)
χ^2	828*		820*		884*		873*		844*		872*		783*	
TLI	.92		.93		.92		.93		.93		.93		.94	
RMSEA	.07		.07		.08		.08		.08		.08		.08	

<i>Female</i>	2		3		4		5		6		7		8	
	<i>b</i>	(SE)	<i>b</i>	(SE)	<i>b</i>	(SE)	<i>b</i>	(SE)	<i>b</i>	(SE)	<i>b</i>	(SE)	<i>b</i>	(SE)
Path A	.33*	(.08)	.37*	(.07)	.33*	(.07)	.38*	(.06)	.34*	(.07)	.43*	(.07)	.41*	(.07)
Path B	.26*	(.07)	.29*	(.09)	.26*	(.09)	.24*	(.11)	.31*	(.10)	.19*	(.10)	.21	(.14)
Path C	.40*	(.08)	.15	(.10)	.28*	(.11)	.06	(.10)	-.14	(.11)	.31*	(.11)	.15	(.12)
Indirect A-B	.09*	(.03)	.11*	(.04)	.08*	(.04)	.09*	(.04)	.10*	(.04)	.08	(.04)	.08	(.06)
<i>AED total effect</i>	.48*	(.08)	.26*	(.09)	.36*	(.09)	.15	(.09)	-.04	(.10)	.39*	(.09)	.23*	(.10)
χ^2	276*		305*		310*		294*		290*		322*		323*	
TLI	.90		.91		.89		.91		.90		.89		.92	
RMSEA	.08		.09		.09		.10		.09		.10		.09	

SE = standard error; TLI = Tucker-Lewis Index; RMSEA = root mean square error approximation

* $p \leq .05$

Table 5.8. RYDS Three-Wave Structural Models of AED, Violence, and Number of Sexual Partners (Standardized Coefficients)

	4		5		6		7	
	<i>b</i>	(SE)	<i>b</i>	(SE)	<i>b</i>	(SE)	<i>b</i>	(SE)
Path A	.32*	(.04)	.37*	(.04)	.36*	(.04)	.39*	(.04)
Path B	.27*	(.05)	.35*	(.06)	.22*	(.06)	.25*	(.06)
Path C	.14*	(.06)	.01	(.06)	.09	(.07)	.09	(.07)
Path D	.14*	(.05)	.01	(.05)	.11*	(.05)	.17*	(.06)
Path E	.01	(.05)	.06	(.05)	-.06	(.06)	-.03	(.05)
Path F	.26*	(.05)	.41*	(.05)	.32*	(.06)	.24*	(.06)
Indirect A-B	.09*	(.02)	.12*	(.03)	.08*	(.02)	.10*	(.03)
Indirect A-B-F	.02*	(.01)	.05*	(.01)	.03*	(.01)	.02*	(.01)
Indirect A-D	.04*	(.02)	.00	(.02)	.04*	(.02)	.07*	(.02)
Indirect C-F	.04*	(.02)	.00	(.03)	.03	(.02)	.02	(.02)
<i>Total effects:</i>								
<i>AED_t → Violence_{t+1}</i>	.23*	(.06)	.13*	(.06)	.17*	(.06)	.19*	(.06)
<i>Total effects:</i>								
<i>AED_t → Partners_{t+2}</i>	.11*	(.05)	.12*	(.05)	.03	(.05)	.08	(.05)
χ^2	1279*		1243*		1240*		1292*	
TLI	.93		.93		.93		.93	
RMSEA	.07		.08		.08		.08	

SE = standard error; TLI = Tucker-Lewis Index; RMSEA = root mean square error approximation
 * $p \leq .05$

Table 5.9. RYDS Three-Wave Structural Models of AED, Violence, and Pregnancy (Standardized Coefficients)

	3		4		5		6		7	
	<i>b</i>	(SE)	<i>b</i>	(SE)	<i>b</i>	(SE)	<i>b</i>	(SE)	<i>b</i>	(SE)
Path A	.36*	(.04)	.32*	(.04)	.37*	(.04)	.36*	(.04)	.39*	(.04)
Path B	.20*	(.06)	.27*	(.05)	.35*	(.06)	.22*	(.06)	.25*	(.06)
Path C	.17*	(.06)	.14*	(.06)	.01	(.06)	.09	(.07)	.09	(.07)
Path D	.04	(.07)	.07	(.06)	.06	(.07)	.12*	(.06)	.12*	(.06)
Path E	.07	(.07)	.20*	(.06)	.15*	(.06)	.10	(.06)	.08	(.06)
Path F	.25*	(.07)	.18*	(.07)	.17*	(.07)	.16*	(.07)	.15*	(.06)
Indirect A-B	.07*	(.02)	.09*	(.02)	.13*	(.03)	.08*	(.02)	.10*	(.03)
Indirect A-B-F	.02*	(.01)	.02*	(.01)	.02*	(.01)	.01*	(.01)	.01*	(.01)
Indirect A-D	.02	(.02)	.02	(.02)	.02	(.02)	.04*	(.02)	.05*	(.02)
Indirect C-F	.04*	(.02)	.03	(.01)	.00	(.01)	.01	(.01)	.01	(.01)
<i>Total effects</i>										
<i>AED_t → Violence_{t+1}</i>	.24*	(.05)	.23*	(.06)	.14*	(.06)	.17*	(.06)	.19*	(.06)
<i>Total effects</i>										
<i>AED_t → Pregnancy_{t+2}</i>	.15*	(.06)	.27*	(.06)	.20*	(.06)	.16*	(.05)	.15*	(.05)
χ^2	1226*		1274*		1251*		1251*		1302*	
TLI	.93		.93		.93		.93		.93	
RMSEA	.07		.07		.08		.08		.08	

SE = standard error; TLI = Tucker-Lewis Index; RMSEA = root mean square error approximation

* $p \leq .05$

CHAPTER 6

AED and Gang Membership

After creating AED proxy measures and estimating their effects on general violence in Chapters 4 and 5, I now examine the effects of the AED latent measures on individual gang activity. These analyses rely completely on the RYDS data. I forego studying gang involvement using the Add Health data for a few reasons. First, Add Health only asks about gang involvement at Waves II (“Have you been initiated into a named gang?”) and III (“Have you ever belonged to a named gang?”), with no validating follow-up questions at either wave. Furthermore, about two-thirds of the 149 youth in the sample who reported initiation into a gang at Wave II reported at the following wave that they had never belonged to a gang. Due to these limitations, I do not have confidence in the Add Health data to accurately measure gang involvement.

However, RYDS provides such rich information about gang activity that the study’s principal investigators have published an award-winning book on the subject of gangs and delinquency in the RYDS data (Thornberry et al., 2003). I draw on the depth of the RYDS gang data in this chapter, exploring the relationships between AED and prevalence, duration, and stability of individuals’ gang membership. Given the differences in measurement of the gang variables of interest, I apply several different analytical techniques, described below.

Gang Membership

To evaluate AED and prevalence of gang membership, I use structural equation modeling, following the same model I used the analysis of AED and violence. Gang membership, measured at waves 2 through 9, is a dichotomous variable coded 1 if a subject reported being a member of a “street gang or posse” since the date of the last interview.

The model estimated in this chapter is visually represented in the path diagram in Figure 2.1. I examine the effects of AED on low self-control (path A), low self-control on gang membership (path B), AED on gang membership directly (path C), and AED on gang membership indirectly, through low self-control (indirect path A-B).

Table 6.1 displays the results of the SEMs modeling AED and gang membership in the full RYDS sample. The numbers across the tops of the columns represent the wave at which AED is measured (t), with gang membership measured at the following wave ($t+1$). Measurement of low self-control occurs at wave 10; this variable is used in all of the models under Gottfredson's and Hirschi's (1990) assumption that self-control is an invariable personality trait.

As Table 6.1 demonstrates, the relationship between AED and low self-control (path A) remains similarly strong across all waves, ranging from .32 (wave 4) to .39 (waves 7 and 8), with all path A coefficients reaching significance at a level of $p \leq .001$. The direct effect of AED on gang membership (path C) is positive and statistically significant in waves 2 ($b = .15, p \leq .05$) and 3 ($b = .16, p \leq .05$), but becomes nonsignificant after the wave 3 model.

The indirect effect of AED on gang membership via low self-control remains significant at a level of $p \leq .001$ across all waves, with coefficients ranging from .07 (wave 2) to .15 (wave 7). The total effect of AED on gang membership declines over time, starting at .22 ($p \leq .001$) in the wave 2 model and falling to .02 (ns) at the wave 8 model. A comparison of the direct effect of low self-control with the total effect of AED indicates that they are equally influential at wave 2 but low self-control is a more important predictor at subsequent waves, with coefficients as large as .43 ($p \leq .001$). The total effect of AED on gang membership is nonsignificant beyond

wave 3, while low self-control remains a strong predictor of gang membership throughout adolescence.

The model fit statistics are largely similar for the seven full-sample models displayed in Table 6.1. The TLI values are acceptable for all models, ranging from .92 to .94. The RMSEA values are adequate.

Differences by sex.

As before, I also estimate the SEMs by sex, to determine whether the effects of AED and low self-control on gang membership vary by sex. Because the RYDS sample is 72% male, the male-only model results are similar to the results for the full-sample model. The usefulness of estimating the models by sex is in more accurately modeling the relationships for the female subjects.

The upper section of Table 6.2 presents the male-only model results; the female model results are in the lower portion of the table. I estimate the model for the female sample for waves 2 and 3 only, when gang membership is measured at waves 3 and 4 ($t+1$). I do not include the later waves because waves 5 through 9 each contained fewer than seven female gang members. As in Chapter 5, I calculate z scores to allow for comparison of the coefficients in the sex-separated models (see Appendix C). There are no significant differences between the coefficients for the male- and female-only wave 2 models. However, the sexes do differ significantly in the wave 3 model, on the path B, path C, and total effect coefficients. Specifically, low self-control is a much stronger predictor of gang membership for females than males. Conversely, AED has positive, strong, and significant direct and total effects on gang membership for males but not females in the wave 3 model. These results indicate that at about age 15, AED affects gang membership six months later for males, while low self-control more strongly predicts gang

membership six months later for female RYDS participants. Few females report gang membership at wave 4 ($N = 19$), and the ones who do have little control over their impulses or tempers. These same individuals have average levels of AED. Following life history theory, I am not surprised that AED does not predict gang membership for females, as it gives little advantage in finding a strong mate with whom to achieve reproductive success.

In the models where AED is measured at waves 4 through 8, the male-sample results are very similar to the full-sample results, as previously discussed. In the later waves, low self-control is a much stronger predictor of gang membership than AED. The only exception is wave 6, where AED's total effect of .20 is similar to the coefficient for low self-control (.17).

These findings do not unambiguously support the hypothesis that higher levels of AED encourage gang membership for males but not females. Instead, it appears that AED affects gang membership for females and males both in the earlier waves, but self-control mediates this relationship, particularly for females. Also, the relationship between low self-control and gang membership grows stronger as adolescents approach adulthood, while the importance of AED weakens. It seems that adolescents with higher levels of AED, particularly girls, quickly mature and begin behaving more cautiously after experimenting with risky behaviors in early- to mid-adolescence. Those with low self-control, on the other hand, persist in delinquency into late adolescence and early adulthood.

In the full-sample models, AED predicts gang membership only in the first two models, when AED is measured at around ages 14.5 to 15. The influence of low self-control on gang membership remains strong and significant throughout adolescence. Additionally, AED significantly affects gang membership indirectly through low self-control in all of the models.

Taken together, the results indicate that AED does predict whether one reports gang membership in mid-adolescence, but in later adolescence, low self-control holds more sway.

These models test only whether or not one joins a gang, but there are many other important questions about whether and how AED influences gang activity. In the remainder of this chapter, I explore how AED affects the duration and stability of gang membership among individuals in the RYDS sample.

Duration of Gang Membership

Next, I evaluate the effects of AED and low self-control on duration of gang membership, that is, how many waves a subject reports gang membership, from waves 2 through 9. This variable ranges from 0 to 8, with a mean of 0.62 because most subjects never join a gang, and most of those who do join a gang leave it quickly. This variable is not normally distributed, as 71% of the RYDS subjects have a value of 0 for the gang duration measure ($N = 573$).

Table 6.3 presents the results of a negative binomial regression predicting duration of gang membership, estimated using Mplus 5 (L. K. Muthén & Muthén, 2007). I underwent several steps to select the negative binomial distribution for this analysis. First, upon examining the dependent variable's descriptive statistics, I noticed that the distribution was skewed toward 0 and that the variance (1.56) was much greater than the mean (0.62), signifying likely overdispersion and suggesting that a negative binomial model is most appropriate in this context. To confirm, I estimated Poisson, negative binomial, and zero-inflated Poisson and negative binomial regressions and compared the Bayesian information criterion (BIC) values to select the best-fitting model. The negative binomial model had the smallest BIC statistic (1634.63), indicating the best fit for the data. Additionally, the dispersion parameter value for the negative

binomial regression significantly differs from 0, verifying the presence of overdispersion and confirming that a Poisson model is inappropriate for the data.

Mplus 5 does not allow for estimation of indirect effects with a negative binomial model, so Table 6.3 contains only the unstandardized coefficients and standard errors for AED (measured at wave 2) and low self-control.²³ I control for sex by adding a variable coded 1 for male respondents and find that one's sex does not significantly affect length of gang membership. In examining the independent variables of interest, I find a nonsignificant relationship for AED, but low self-control is highly predictive of duration of gang membership, with an unstandardized coefficient of 0.96 ($p \leq .001$). For each one-standard deviation increase in the low self-control factor, the expected log count of the number of waves in a gang increases by almost one wave.

Low self-control likely mediates the relationship between AED and gang duration, rendering AED nonsignificant here. In a negative binomial model without self-control (results not charted here), AED significantly predicts gang duration with an unstandardized coefficient of 1.16 ($p \leq .001$). This is in line with the structural models predicting gang membership, where AED affects membership indirectly, via low self-control.

The negative binomial model predicting the number of waves in which a participant reports gang membership indicates that, of the variables in the model, low self-control is the only significant predictor of gang duration. Although AED likely has a significant effect, it is mediated by low self-control. As with the other models, it's probable that omitted variables predict duration of gang membership. However, because of the dissertation's paramount goal of

²³ I estimated this equation with AED measured at other waves and received similar findings. I present only the wave 2 findings, measuring AED prior to most instances of gang membership.

comparability between Add Health and RYDS datasets, I constrain this model to keep it as simple as the others.

In this and the prior section, I find that although AED affects gang membership and duration, it is mediated by low self-control, which exerts a stronger influence on both of these dependent variables. In the next and final portion of the gang analysis chapter, I explore the relationships between AED, low self-control, and the stability of one's gang membership.

Stability of Gang Membership

Table 6.4 presents the results of a multinomial logistic regression model predicting individuals' stability of gang membership. To estimate this model, I extract the latent variables created in Mplus and import the data to SAS (SAS Institute Inc., 2010). The three categories of gang stability are compared to a reference group of nongang youth ($N = 573$). The short-term category consists of subjects who participate in a gang for one wave only ($N = 101$); youth in the intermittent category report multiple waves of membership but with at least one break ($N = 82$); long-term gang members are those who report multiple consecutive waves of gang membership without any breaks ($N = 48$).

As Table 6.4 shows, all three categories of gang members are significantly more likely to have low self-control than their nongang peers, and short- and long-term gang members are also more likely to anticipate an early death. Perhaps the most interesting finding in this analysis is the finding that intermittent gang members are not significantly different from nongang youth in terms of AED, but this group has the largest unstandardized coefficient for low self-control by far. A one-standard deviation increase in the low self-control factor with other variables held constant increases the log-odds for intermittent gang membership relative to non-membership by 1.45 ($p \leq .001$). The results shown in Table 6.4 indicate that intermittent gang members are

different – compared to short- and long-term gang members (relative to nongang youth), intermittent gang members are less likely to expect to die young and more likely to have low self-control. The intuitive conclusion to draw from Table 6.4 is that individuals with poor impulse or temper control continue to join a gang even after exiting the group one or more times; they just can't stay away.

Higher levels of both AED and low self-control are significantly associated with both short- and long-term gang membership, compared to nongang youth. The coefficients for these two stability categories are similar in terms of direction, magnitude, and significance.

Summary

In this chapter, I examine the effects of the latent measures of AED on individuals' prevalence, duration, and stability of gang membership in the RYDS dataset. In the full-sample structural models, AED predicts gang membership only in the first two models, when AED is measured at around ages 14.5 to 15. The influence of low self-control on gang membership remains strong and significant throughout adolescence, though. Additionally, AED significantly affects gang membership indirectly through low self-control in all of the models. Taken together, the results indicate that AED does impact whether one reports gang membership in mid-adolescence, but in later adolescence, low self-control exerts more influence.

The sex-separated structural models reveal some interesting differences. These findings show that AED affects gang membership for females and males alike in the earlier waves, but self-control moderates this relationship, particularly for females. Also, the relationship between low self-control and gang membership grows stronger as adolescents approach adulthood, while the importance of AED weakens. This is the same pattern I discover in Chapter 5's exploration of violence.

Next, I estimate a negative binomial model predicting the number of waves in which a participant reported gang membership. Of the variables in the model, low self-control is the only significant predictor of gang duration. If AED affects gang duration, it is mediated by self-control. This is likely, given the results of the structural models that show AED influencing gang membership indirectly through low self-control. As with the other models, it's probable that omitted variables predict duration of gang membership. However, because of the principal goal of comparability between Add Health and RYDS datasets, I constrain this model to maintain simplicity.

In the final analysis in this chapter, I study the relationships between AED, low self-control, and stability of gang membership. The multinomial logistic regression reveals that all three categories of gang members (i.e., short-term, intermittent, and long-term) are significantly more likely to have low self-control than their nongang peers, and short- and long-term gang members are also more likely to anticipate an early death. The most fascinating finding in this analysis is the discovery that intermittent gang members are no different from nongang youth in terms of AED, but low self-control substantially increases the likelihood of intermittent gang membership – with other variables held constant, a one-standard deviation increase in the low self-control factor increases the log-odds for intermittent gang membership relative to non-membership by 1.45 ($p \leq .001$). It appears that after exiting a gang, individuals with low self-control keep coming back.

Higher levels of both AED and low self-control are significantly associated with both short- and long-term gang membership, compared to nongang youth. The coefficients for these two stability categories are similar in terms of direction, significance, and magnitude, but AED might play different roles for these groups. Those who do not foresee a long future may join a

gang for protection (i.e., to improve their chances of survival) or because they feel they have nothing to lose and gang involvement seems enjoyable. Similarly, AED could drive either desistance from gang activity (logically, exposure to violence should encourage one to avoid that environment) or sustained gang involvement (if one feels no sense of control over what happens). This underlines the importance of disentangling the causal relationship between AED and risk-taking behaviors.

In both the structural models predicting gang membership and the negative binomial model predicting length of time in the gang, I find that although AED affects both gang membership and duration, its effect is mediated by low self-control, which exerts a stronger influence on both of these dependent variables than does AED. Upon exploring the stability of gang membership, though, I find that low self-control is a stronger predictor of intermittent gang membership specifically. Conversely, AED exerts a stronger influence on both short- and long-term gang membership patterns, compared to self-control. It is clear that AED and low self-control are interrelated and have varying effects on risky behaviors.

In the next and final analysis chapter, I delve into an understudied and critical question in the criminological AED literature – which comes first, risky behavior or future discounting?

Table 6.1. Structural Models of AED and Gang Membership (Standardized Coefficients)

	2		3		4		5		6		7		8	
	<i>b</i>	(SE)	<i>b</i>	(SE)	<i>b</i>	(SE)	<i>b</i>	(SE)	<i>b</i>	(SE)	<i>b</i>	(SE)	<i>b</i>	(SE)
Path A	.33*	(.04)	.36*	(.04)	.32*	(.04)	.37*	(.04)	.36*	(.04)	.39*	(.04)	.39*	(.04)
Path B	.22*	(.06)	.37*	(.07)	.43*	(.08)	.39*	(.09)	.28*	(.08)	.39*	(.09)	.34*	(.12)
Path C	.15*	(.07)	.16*	(.08)	-.07	(.08)	-.05	(.09)	.02	(.08)	-.11	(.09)	-.11	(.11)
Indirect A-B	.07*	(.02)	.13*	(.03)	.14*	(.03)	.14*	(.04)	.10*	(.03)	.15*	(.04)	.13*	(.05)
<i>AED total effect</i>	.22*	(.06)	.29*	(.07)	.07	(.07)	.09	(.08)	.12	(.08)	.04	(.09)	.02	(.09)
χ^2	1208*		1205*		1251*		1243*		1216*		1284*		1202*	
TLI	.92		.93		.93		.93		.93		.93		.94	
RMSEA	.07		.07		.08		.08		.08		.08		.08	

SE = standard error; TLI = Tucker-Lewis Index; RMSEA = root mean square error approximation

* $p \leq .05$

Table 6.2. Structural Models of AED and Gang Membership by Sex (Standardized Coefficients)

<i>Male</i>	2		3		4		5		6		7		8	
	<i>b</i>	(SE)	<i>b</i>	(SE)	<i>b</i>	(SE)	<i>b</i>	(SE)	<i>b</i>	(SE)	<i>b</i>	(SE)	<i>b</i>	(SE)
Path A	.35*	(.05)	.36*	(.05)	.33*	(.05)	.39*	(.05)	.39*	(.05)	.40*	(.05)	.39*	(.04)
Path B	.18*	(.08)	.28*	(.09)	.38*	(.09)	.40*	(.09)	.17*	(.09)	.41*	(.11)	.39*	(.13)
Path C	.16*	(.08)	.30*	(.09)	-.01	(.08)	-.04	(.09)	.13	(.10)	-.29*	(.09)	-.13	(.12)
Indirect A-B	.06*	(.03)	.10*	(.03)	.12*	(.03)	.15*	(.04)	.07	(.04)	.16*	(.05)	.15*	(.05)
<i>AED total effect</i>	.22*	(.07)	.40*	(.08)	.11	(.08)	.11	(.08)	.20*	(.09)	-.13	(.08)	.02	(.11)
χ^2	817*		817*		872*		870*		835*		935*		792*	
TLI	.92		.93		.93		.93		.93		.93		.94	
RMSEA	.07		.07		.08		.08		.08		.08		.08	

<i>Female</i>	2		3	
	<i>b</i>	(SE)	<i>b</i>	(SE)
Path A	.33*	(.08)	.37*	(.07)
Path B	.37*	(.09)	.66*	(.14)
Path C	.09	(.12)	-.29	(.15)
Indirect A-B	.12*	(.04)	.24*	(.08)
<i>AED total effect</i>	.21	(.11)	-.05	(.13)
χ^2	275*		300*	
TLI	.90		.91	
RMSEA	.08		.09	

SE = standard error; TLI = Tucker-Lewis Index; RMSEA = root mean square error approximation

* $p \leq .05$

Note: Female-only models are not estimated for AED measured at waves 4 through 8 because waves 5 through 9 (i.e., $t+1$) all had fewer than 10 female gang members.

Table 6.3. Negative Binomial Model Predicting Duration of Gang Membership

(Unstandardized Coefficients)

	Coef.	(SE) -
Male	0.20	(.17)
AED ₂	0.45	(.32)
Low self-control	0.96***	(.15)
Intercept	-0.80***	(.15)
Log likelihood	-800.59	-

*** $p \leq .001$ -

**Table 6.4. Multinomial Logistic Regression Predicting Stability of Gang Membership
(Unstandardized Coefficients)**

	Short-term		Intermittent		Long-term	
	Coef.	(SE)	Coef.	(SE)	Coef.	(SE)
Male	-0.22	(.24)	0.57	(.33)	-0.46	(.32)
AED ₂	1.40**	(.51)	0.44	(.55)	1.50*	(.71)
Low self-control	0.58**	(.22)	1.45***	(.24)	0.83**	(.31)
Intercept	-1.64	(.19)	-2.61	(.30)	-2.28	(.26)

Likelihood ratio $\chi^2 = 86.24***$ -

* $p \leq .05$; ** $p \leq .01$; *** $p \leq .001$ -

Note: Stability categories are compared with a baseline group of nongang youth.

CHAPTER 7

Autoregressive Cross-Lagged Panel Models

In Chapters 5 and 6, I estimate structural models measuring the effects of AED on violence and gang membership one wave later. These models test the theory that AED encourages adolescents to engage in risk-taking behaviors because they believe they have nothing to lose. However, the reverse may also occur – youths may experience fatalistic beliefs because of their engagement in dangerous and risky behaviors.

Previous research found reciprocal effects between AED and risky health behaviors – AED predicted later risky health behaviors and vice versa (Borowsky et al., 2009). A key benefit of the RYDS data is the large number of observations periods, monitoring a sample of at-risk youth at six-month intervals throughout their teenaged years. The use of many waves of data, especially collected so close in time, allows for a better understanding of how AED and risky behaviors change and influence each other over time. To further examine this relationship, I employ cross-lagged panel models using waves 2 through 9 of the RYDS, as illustrated in Chapter 2 (Figure 2.2). As with the previous SEMs, I estimate the models using the Mplus software program (L. K. Muthén & Muthén, 2007).

An autoregressive cross-lagged panel model measures the effect of one construct on another measured at a later time, accounting for previous levels of the dependent variable (Selig & Little, 2012). In the context of my dissertation, I estimate the effect of risk-taking behaviors at wave t on AED at wave $t+1$, and vice versa – this is the cross-lagged portion of the model. The autoregressive component of the model controls for the effect of each variable at one period on the same variable at the next period (e.g., the effect of AED_t on AED_{t+1}). Additionally, the model

estimates the correlation between the variables at the first wave in the model. The autoregressive component of the model allows the researcher to rule out the likelihood that an apparent cross-lagged effect is in fact due to a correlation between the variables at the first time period (Selig & Little, 2012, p. 266). The autoregressive cross-lagged panel model is somewhat difficult to understand in text, but becomes very clear when illustrated. To present the findings as clearly as possible, this chapter's results are presented in minimalist figures including only coefficients and asterisks denoting significance at a level of $p \leq .05$; standard errors are available upon request.

AED and Violence Prevalence

I first estimate the models with AED and violence prevalence. To preserve the simplicity and clarity of the model, I forego inclusion of covariates.²⁴ However, as with the structural models estimated in Chapters 5 and 6, I estimate separate models by sex.

Figure 7.1 presents the results of the autoregressive cross-lagged structural model of AED and violence for the full RYDS sample. The correlation between AED and violence at wave 2 is statistically significant at .18 ($p \leq .001$), indicating a relationship between the two variables. Both AED and violence demonstrate high stability. The average of the stability coefficients for AED is .87; this variable is highly stable from one wave to the next. For violence, the stability coefficient from wave 2 to wave 3 is .53, much lower than those for the other between-wave relationships (although still highly significant). This is likely because violence is most prevalent at wave 2, with participation in violent activity declining steeply by wave 3. In wave 2, over a third of the sample report violence ($N = 278$); in wave 3 that number declines by 19%, to 224. In wave 4, 216 respondents report violence, a decline of just 4% from

²⁴ Also, Mplus does not compute standard errors or significance statistics when covariates are included in a robust weighted least squares model. Given the choice, I opt to estimate a simpler model with standard errors and significance tests rather than one with covariates but a hampered ability to interpret the findings.

the prior wave. The stability coefficients for the later waves are stronger, then, because most individuals have completed the experimentation phase and are more consistently violent or nonviolent from wave to wave.

The key relationships of interest in the model presented in Figure 7.1 are represented by the diagonal lines in the middle of the figure. These lines represent the relationship of one variable measured at one wave (t) on the other variable measured six months later, at the subsequent wave ($t+1$). There are few significant coefficients on these lines. The largest coefficient in the middle area of the figure is .16 ($p \leq .001$), for the relationship of AED at wave 2 on violence at wave 3. This indicates that AED at about age 14.5 strongly predicts violence at age 15.

There are three other significant coefficients in the model. The relationship from wave 5 violence to AED at wave 6 is significant ($b = -.08, p \leq .01$), indicating that engaging in violence at around age 16 is related to decreased AED six months later. The negative relationship is unexpected and counterintuitive. However, scholars have found that youths growing up in dangerous environments often use violence to gain a sense of power and invincibility (Anderson, 1999; Lorion & Saltzman, 1993; Silberman, 1978; Tolleson, 1997). This significant negative relationship, indicating that those who engage in violence have a lower subsequent score on the AED factor, therefore has some support in prior research. The other significant relationships are from wave 6 (age 16.5) to wave 7 (age 17). AED at wave 6 significantly predicts violence at wave 7 ($b = .13, p \leq .01$) and violence at wave 6 predicts AED six months later ($b = .08, p \leq .01$). These relationships are in the expected direction.

Although there are some sporadic significant coefficients, the model presents no clear pattern between AED and violence engagement throughout adolescence. Future research should

explore these relationships throughout adolescence in greater depth, to determine whether, how, and why AED and violence influence each other differently at certain ages.

Differences by sex.

Figure 7.2 presents the results of sex-separated autoregressive cross-lagged panel models of AED and violence prevalence. In the model for males only, the sole significant cross-lagged relationship is the one between AED at wave 6 and engagement in violence at wave 7 ($b = .16$, $p \leq .01$). The lack of a cross-lagged relationship for males is surprising given the existing literature demonstrating a link between fatalistic attitudes and violence among males (Alexander, 1979; Ellis et al., 2012; Wilson & Daly, 1985). One possible explanation is that the period of examination here begins too late. The autoregressive component of the model allows one to rule out the possibility that the effect of one variable on the other is merely due to the correlation between the variables at the first observation period, rather than a causal mechanism at later waves. It's possible that this explains the unexpected findings here, particularly in view of the findings from Chapter 5, where AED directly and indirectly affects violence in the two-wave SEMs. Those significant coefficients may have actually been due to an earlier correlation between the variables. To clarify the relationship between AED and violence, then, it's likely necessary to begin the observation prior to adolescence. A longitudinal study of youth measuring AED and externalizing behaviors beginning at younger ages might be necessary to identify when AED begins, and to determine whether it affects delinquency.

The autoregressive cross-lagged model for females also reveals some interesting and unexpected findings. AED predicts engagement in violence from waves 2 to 3 ($b = .37$, $p \leq .001$), 3 to 4 ($b = -.27$, $p \leq .01$), and 4 to 5 ($b = .23$, $p \leq .05$). Conversely, violence significantly predicts AED from waves 5 to 6 ($b = -.14$, $p \leq .05$) and 6 to 7 ($b = .19$, $p \leq .001$).

These fascinating patterns in the females-only model suggest that AED influences violence in earlier adolescence, but violence affects AED in later adolescence. However, the findings do not present a straightforward pattern. AED increases the likelihood of violent engagement from waves 2 to 3 and 4 to 5. Conversely, AED lowers the likelihood of violence from wave 3 to 4. The reason for the change in the direction of the relationship is unclear. Something similar occurs later – violence is linked to lower AED from waves 5 to 6 but higher AED from waves 6 to 7. Again, it's unclear why violence would decrease AED in one part of the model but increase AED in the next segment. One possible explanation is that just a few females who engage in violence drive the findings due to their outlier status. This is likely, given that some waves contain as few as 20 (9%) females who engage in violence. At most waves, just one violent female has a low level of AED (i.e., her AED factor score is less than the variable mean minus one standard deviation). However, in a couple of waves, multiple violent females (three at wave 4, six at wave 6) fall in the low AED range. With such a small sample, a few surprising values can result in unexpected findings.

As with the sex-separated structural models estimated in the previous chapters, I also estimate z scores to evaluate the differences between the coefficients for the male- and female-only models (Appendix C). The difference-of-coefficients tests reveal a number of significant differences between the sexes. The coefficients for the paths from AED_2 to $violence_3$ ($z = -2.70$) and AED_7 to $violence_8$ ($z = -2.38$) are significantly larger for females than males, indicating that AED more strongly predicts engagement in violence for females than for males, at least around ages 14 and 17, although the coefficient for AED_7 to $violence_8$ is not significant. The finding for wave 2 AED may result from the same explanation proposed in Chapter 5's description of differences in AED and violence prevalence by sex. It appears that females must reach a higher

threshold of AED before they become violent, whereas males with any level of AED might engage in violence.

I find the opposite for another path – the coefficient for the path from AED_3 to $violence_4$ ($z = 2.87$) is larger for males than females. However, the coefficient in the males-only model is nonsignificant, while the females-only model coefficient is negative and highly significant ($b = -.27, p \leq .01$). For females, higher AED at wave 3 corresponds to a lower likelihood of violent engagement six months later. This finding is likely driven by a few violent females with low AED values.

The model fit statistics for the male models are similar to those for the full-sample models, but the fit statistics for the female models are worse than for the full-sample models. The TLI of .92 reaches the threshold of acceptability. The RMSEA value for the females-only model is .09; an RMSEA greater than .08 indicates a poor model fit (Schumacker & Lomax, 2010). Taken together, these fit statistics indicate that the model is a poorer fit for the females relative to the males.

AED and Gang Membership

Figure 7.3 displays the results of cross-lagged panel models of the relationship between AED and gang membership in the RYDS data. The stability coefficients for both AED and gang membership are all significant at a level of $p \leq .001$. The only statistically significant cross-lagged relationship is the one between AED_2 and $gang_3$ ($b = .19, p \leq .001$), indicating that higher levels of AED at around age 14.5 increase the likelihood of gang membership six months later. The lack of significant findings between later waves may be due to the correlation between AED and gang membership at wave 2, or because gang membership falls off steeply after wave 2 and

there are too few gang members to accurately track the relationship as the RYDS sample ages. Or, it may simply be that AED does not influence gang membership beyond age 15.

This model has the best fit of all the SEMs estimated thus far. The TLI values comfortably reach the traditional cutoff value of .90, and the RMSEA of .06 falls within the acceptable-to-good range. These statistics indicate that the model fits the data well.

Differences by sex.

Figure 7.4 displays the results of the sex-separated autoregressive models of AED and gang membership. Because waves 5 through 9 each have fewer than 10 female gang members, I limit the sex-separated gang membership models to waves 2 through 4.

The left-hand model in Figure 7.4 shows the results of the male-only model. Here, AED significantly predicts gang membership from waves 2 to 3 ($b = .21, p \leq .001$) and 3 to 4 ($b = .18, p \leq .001$). Gang membership does not predict AED. This unambiguously signals the direction of the relationship between AED and gang membership for adolescent males. For male RYDS participants, AED at one wave significantly predicts gang membership six months later, even accounting for the correlation between the variables at wave 2. This suggests that a fatalistic attitude increases the likelihood of taking a risk by joining a gang. The reverse is not true; gang membership does not causally impact AED. Experiencing the danger related to gang membership does not impact the level of fatalism felt by adolescent males.

The model on the right in Figure 7.4 illustrates this relationship for the RYDS female subsample. In this model, the only significant relationships are the correlation between AED and gang membership at wave 2 and the stability coefficients measuring the autoregressive effects. None of the coefficients in the center of the figure, showing the cross-lagged elements of the

model, reach significance. These results indicate no causal relationship between AED and gang membership for females, although the two variables correlate significantly at wave 2.

The results of the sex-separated cross-lagged models of AED and gang membership support the hypothesis that AED influences delinquent behavior for males but not females. This supposition has not found support in the other models estimated in the dissertation, but the models discussed in this section fit the data considerably better than the other models have. The panel models in Figure 7.4 fit the data quite well, with TLIs of .98 and .96 for males and females respectively, and RMSEA values of .05 and .06. What's more, the χ^2 values for the sex-separated models are not statistically significant, indicating a perfect fit for the data. These models provide evidence of a positive and significant effect of AED on gang violence among male subjects, but no cross-lagged relationships between AED and gang membership for females.

Summary

The results of the autoregressive cross-lagged panel models estimated in this chapter add to the complexity of the relationship between AED and risk-taking behavior. Although the two-wave structural models estimated in Chapters 5 and 6 generally show significant direct and/or indirect effects of AED on violence and gang membership six months later, the cross-lagged models do not. This might be partially due to the fact that involvement in violence and gang membership declines sharply after wave 2, resulting in more stable relationships across time during the later waves. One of the limitations of autoregressive models is that they do not describe within-person stability for the variables; a large stability coefficient can indicate several different things (Selig & Little, 2012).²⁵ Another potential explanation for the apparent

²⁵ Here, a large stability coefficient for violence can indicate that: (1) respondents' violent offending does not change over time, (2) respondents uniformly increase or decrease violence levels over time, or (3) respondents systematically increase and decrease in their violent offending over time.

discrepancy between the two-wave SEMs and the panel models is that the effects seen before, in models with shorter timeframes and without an autoregressive component, may be due to an earlier correlation between AED and the risk-taking variables. When the panel models control for these correlations, the cross-lagged effects largely disappear.

The main exception to this finding is in the male-only panel model of AED and gang membership. In this model, AED predicts gang membership six months later, from waves 2 to 3 and 3 to 4. Gang membership does not predict AED. The male-only panel model of AED and gang membership is also the best fit for the data, with fit statistics much better than those for all the other models. This indicates that for males, AED is a causal factor in gang membership, even after controlling for the correlation between AED and gang membership.

To better evaluate the causal relationships between AED and risk-taking behaviors throughout adolescence, future research should estimate autoregressive cross-lagged panel models and begin with younger participants. This will better enable the researcher to identify the point at which AED develops in children, likely prior to any engagement in serious violent activity. Beginning a panel model at an age when AED and delinquency likely do not correlate with each other will improve the chances that clearer causal relationships between AED and risky behaviors will emerge.

This chapter concludes the dissertation's analyses. In the next and final chapter, I synthesize and discuss the results from Chapters 4 through 7, examining the findings and how they fit (or do not fit) within life history theory.

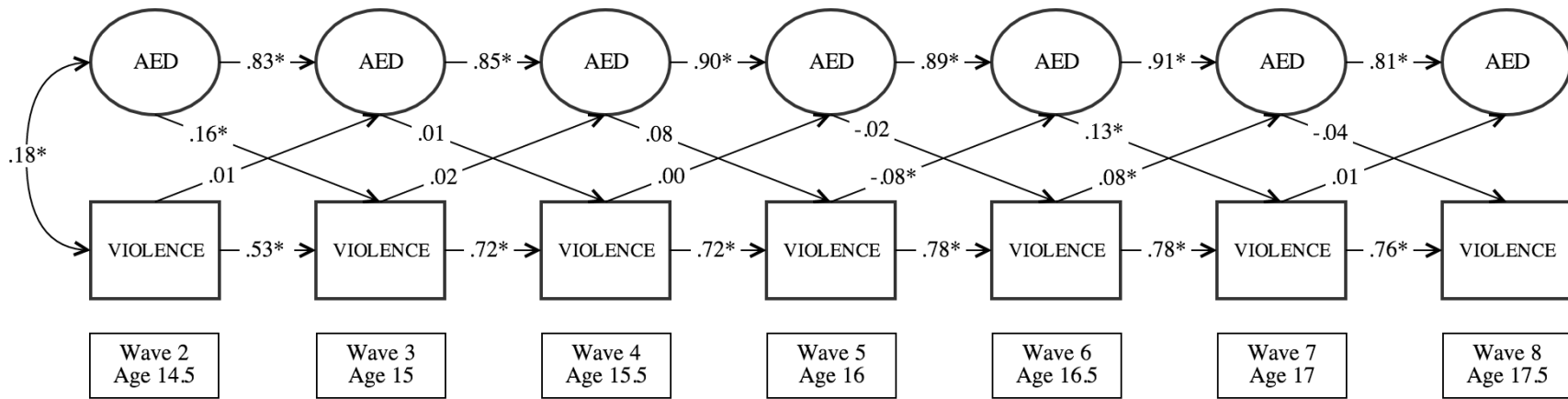
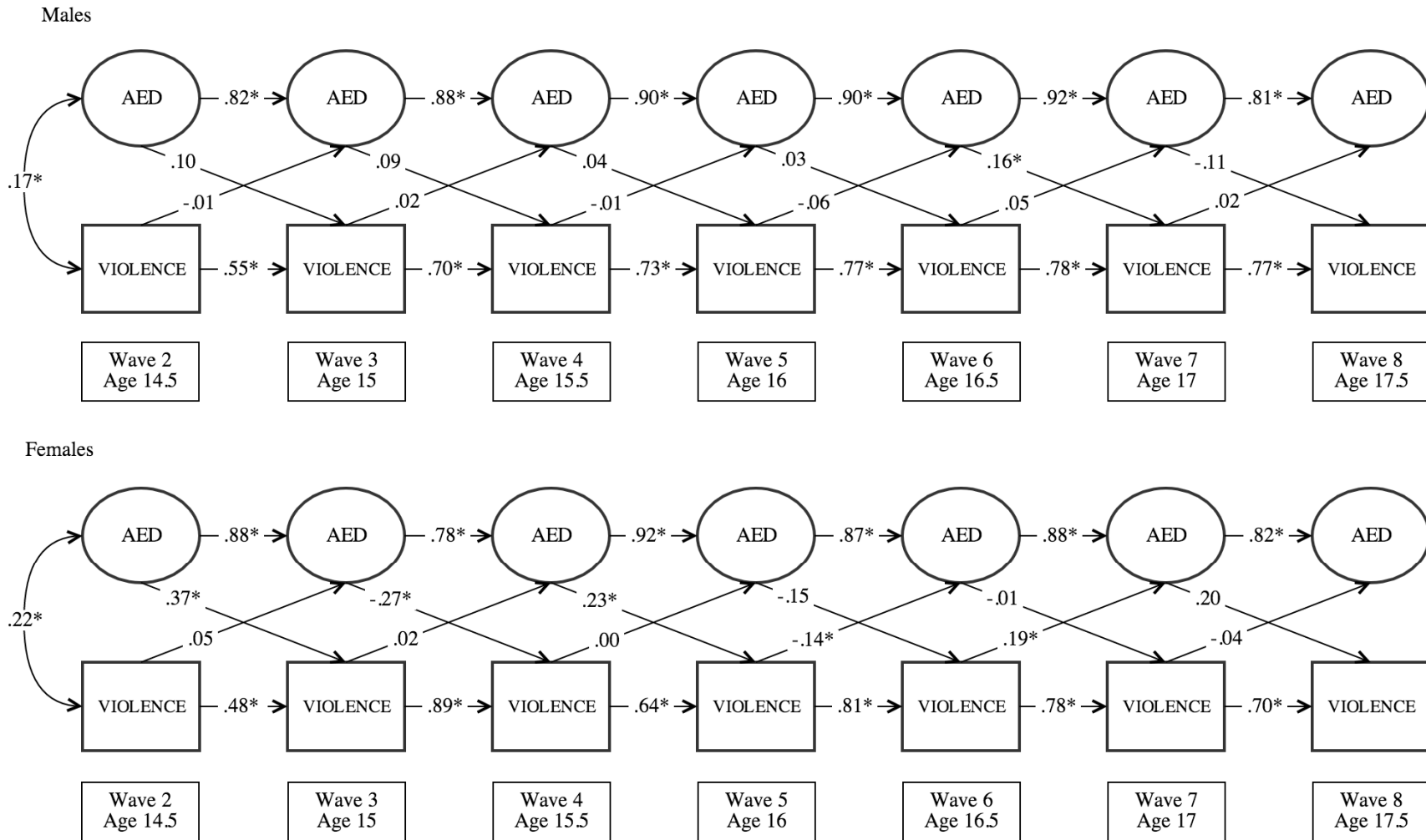
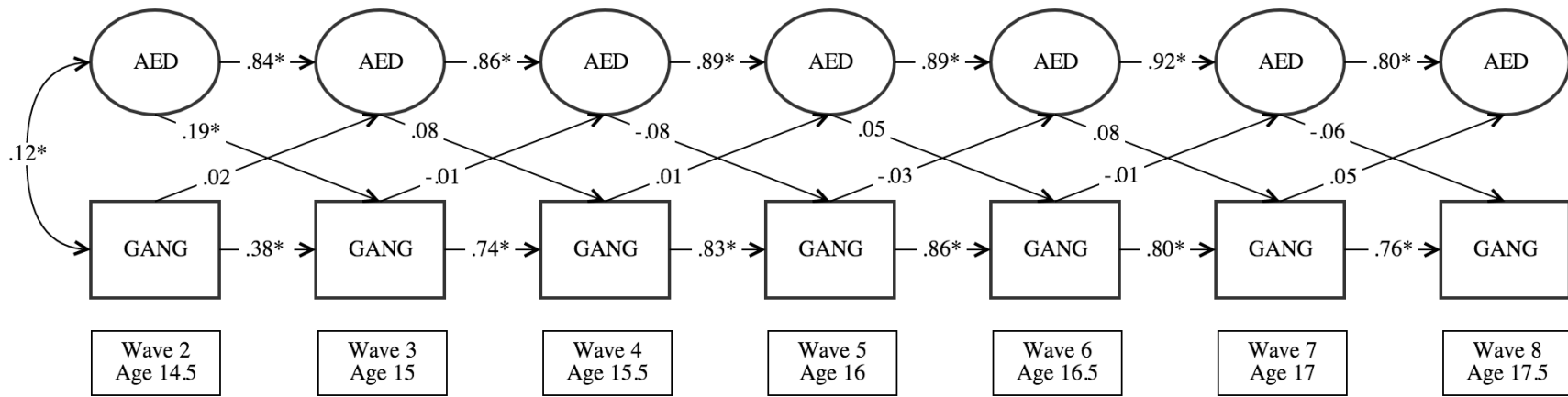

Figure 7.1. Autoregressive Cross-Lagged Panel Model of AED and Violence Prevalence (Standardized Coefficients)



Male-only model fit statistics: $\chi^2 = 153^*$; TLI = .93; RMSEA = .08.
 Female-only model fit statistics: $\chi^2 = 70^*$; TLI = .92; RMSEA = .09.
 * $p \leq .05$.

Figure 7.2. Autoregressive Cross-Lagged Panel Models of AED and Violence Prevalence by Sex (Standardized Coefficients)



Model fit statistics: $\chi^2 = 104^*$; TLI = .96; RMSEA = .06.

* $p \leq .05$.

Figure 7.3. Autoregressive Cross-Lagged Panel Model of AED and Gang Membership (Standardized Coefficients)

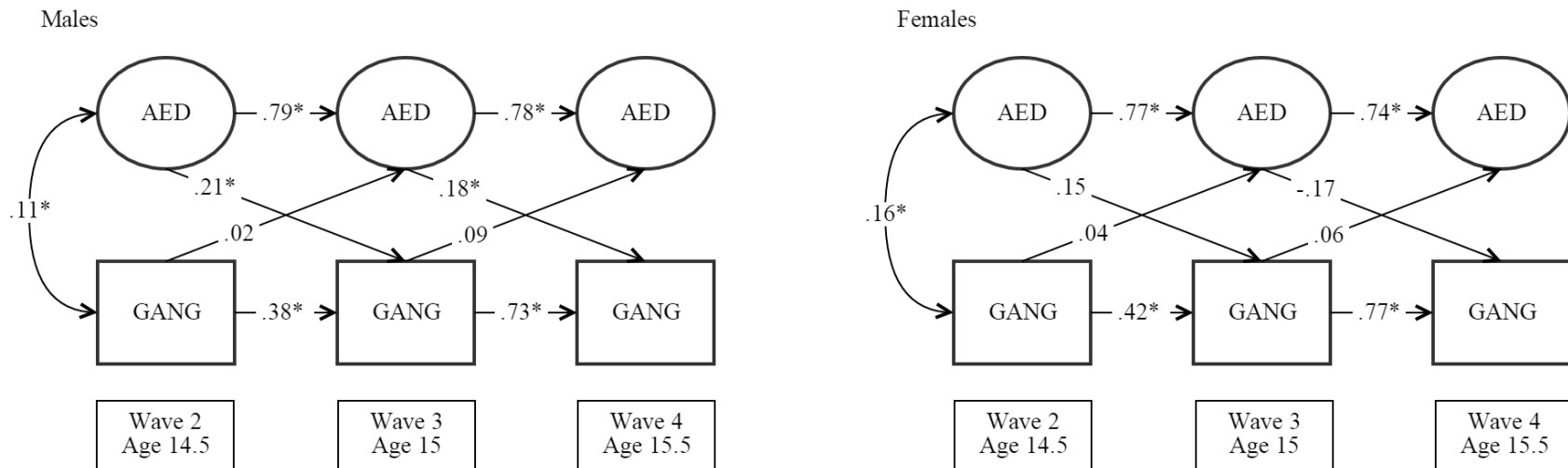

Male-only fit statistics: $\chi^2 = 7.25$ (ns); TLI = .98; RMSEA = .05.
 Female-only fit statistics $\chi^2 = 7.45$ (ns); TLI = .96; RMSEA = .06.
 * $p \leq .05$.

Figure 7.4. Autoregressive Cross-Lagged Panel Models of AED and Gang Membership by Sex (Standardized Coefficients)

CHAPTER 8

Summary and Discussion

This chapter provides a summary and discussion of the dissertation. First, I present an overview of the study and theoretical model. Next, I review the results presented in Chapters 4 through 7. Following this, I discuss the theoretical and policy implications of significant findings. Finally, I conclude with a discussion of the study's limitations and ways in which future research can further explore the relationships between AED and risk-taking behaviors.

Study Overview

This dissertation endeavors to determine the effects of anticipated early death on violent delinquency and gang activity, two specific and especially problematic risk-taking behaviors. Life history theory suggests that exposure to a stressful and negative environment results in AED and a corresponding biological drive to procreate. In this evolutionary framework, females strive to enter a committed, monogamous relationship with a partner who can contribute to the family's childrearing efforts (Sylwester & Pawłowski, 2011). When facing a shortened life expectancy, women may respond by becoming sexually active and pregnant at younger ages (Caldwell et al., 2006; Wilson & Daly, 1997). In contrast, the best way for men to achieve reproductive success is by maximizing the number of sexual partners, to increase the chances that one's genes will be passed on. Fatalism and discounting of the future increase the likelihood of risk-taking behavior because, particularly among young males, such actions can improve one's status and dominance, and, therefore, one's chances of reproductive success. In such situations, males employ a high-stakes, high-reward strategy.

A general aim of this study is to quantify AED, devising a measure researchers can apply to existing and future social science datasets. The specific objectives of the dissertation are as follows:

Objective 1: Operationalize a quantifiable measure of AED.

Objective 2: Examine the impacts of AED on individual violence and gang activity (including gang membership, duration, and stability), two extremely risky behaviors.

Objective 3: Determine the causal ordering of AED and delinquent risk-taking behaviors (i.e., violence and gang activity).

In focusing on these three objectives, this study contributes to the literature in several ways. First, I answer Piquero's (2016) call for additional measures of AED, quantitative studies of AED, use of longitudinal data in exploring AED, and examination of AED in samples of offenders. Caldwell and colleagues (2005) also issued a call for more research on AED to create valid and reliable measures, explore the etiology of AED, and investigate assorted outcomes such as pregnancy and delinquency. To address these gaps in the literature I use two longitudinal datasets to operationalize AED, then capitalize on the sample of at-risk individuals in the Rochester Youth Development Study to examine the effects of AED on criminality over time. Previous quantitative studies on AED in criminology (i.e., Brezina et al., 2009, Piquero, 2016, and Tillyer, 2015) explored its effect on offending in general. This dissertation focuses on violence and gang activity to explore the relationship between AED and these specific risk-taking behaviors.

To quantify AED (Objective 1), I estimate second-order factor analysis models to create latent constructs that measure the shared variance of known AED correlates. The presence of

variables that explicitly measure AED in the Add Health data allows for validation of the factor variables by comparing them with the direct AED measures. Replication of the second-order factor analyses in the RYDS data facilitates latent measurement of AED with strengthened confidence in the measures.

To examine the impacts of AED on violent delinquency and gang activity (Objective 2), I employ structural equation models with the AED factor variables measured at time t and the endogenous delinquency variables measured one wave later, at time $t+1$. To briefly describe the theoretical model (Figure 2.1), I hypothesize that higher levels of AED are associated with greater likelihood of violence and gang involvement. I also expect that low self-control mediates this relationship due to its strong associations with both AED and delinquency. For more specific research questions about gang activity, I estimate a negative binomial regression equation predicting gang duration and a multinomial logistic regression predicting stability of gang membership, with the expectations that higher levels of AED correspond to longer, more stable periods of gang involvement.

In addressing the third objective of the study, I tackle the chief problem in criminological AED research – the establishment of causal ordering of AED and risk-taking behavior. Previous research found reciprocal effects between AED and risky health behaviors (Borowsky et al., 2009), but I know of no prior research testing for reciprocal effects between AED and delinquency. The use of the RYDS data, with its many observation periods collected so close in time, allows me to explore how AED and risky behaviors change and influence each other over time. I accomplish this with autoregressive cross-lagged panel models.

Summary of Results

Measurement of AED.

In Chapter 4, I meet the first study objective by using two secondary datasets to create latent measures of future discounting. Including identical or similar measures in both the Add Health and RYDS models, I find that many of the same variables load strongly to build latent measures of AED in both samples (Table 4.2; Table 4.5). Specifically, depression, low self-esteem, low attachment to parents, and low connection to school all load onto the AED factor variables at each wave in both the Add Health and RYDS datasets.

However, I also find discrepancies between the two data sources. In the Add Health data only, poor academic performance, receipt of public assistance, and living in an unsafe neighborhood (at Wave I) also load onto the latent AED constructs. These variables do not load in the RYDS data, but the measure of parental unemployment does (albeit in waves 3, 5, and 8 only). These findings suggest dissimilarities in the measurement of AED in different samples. The Add Health sample is nationally representative, while the RYDS oversampled males and youths at risk of delinquency. Consequently, the RYDS sample is more homogeneous in several ways; this may account for the non-loading of public assistance receipt and living in an unsafe neighborhood. The divergence in poor academic performance may result from measurement differences in the two datasets (self-reported grade point average in Add Health vs. official standardized math test scores in RYDS). Although there are some differences in AED measurement between Add Health and RYDS, the measurement models are quite similar for the two sexes within each dataset, suggesting that the same factors contribute to AED for males and females alike.

After creating the latent constructs using second-order factor analysis, I evaluate the reliability and validity of the measures to confirm that they measure AED as intended. The use of several different methods (i.e., computation of Cronbach's alpha values and correlations with direct AED measures as well as delinquent and reproductive behaviors) bolsters the validity of the AED factor variables in the Add Health and RYDS samples.

AED and violence.

In Chapter 5, I estimate structural equation models to examine the effects of the latent measures of future discounting on violent behavior in both the Add Health and RYDS samples, testing the theoretical model illustrated in Figure 2.1. These structural models demonstrate that, generally speaking, violent behavior is substantially influenced by AED, low self-control, and AED via low self-control. Low self-control significantly predicts violence in all of the full-sample models presented in Chapter 5 (see Table 5.1, Table 5.4, and Table 5.6). Additionally, AED's indirect effect on violence (through low self-control) is significant in all of the full-sample models for Add Health and RYDS alike. Accordingly, the total effect of AED on violence is significant in the Add Health and RYDS full-sample models.

These findings are consistent with life history theory and with prior research on AED, self-control, and violence. However, the models do not reliably support one hypothesized relationship. The only path lacking a statistically significant coefficient in all of the full-sample Add Health and RYDS models presented in Chapter 5 is the direct effect of AED on violence (path C). In the Add Health data, AED at around age 16 negatively and significantly impacts violence prevalence five years later. Perhaps those with fatalistic attitudes behave with greater caution in early adulthood, in the hopes of improving their life chances. In the RYDS data, AED at ages 14.5 to 15.5 positively and significantly impacts both violence prevalence and variety six

months later. By later adolescence and young adulthood, though, AED no longer predicts violent behavior. Instead, low self-control has a greater influence. It may be the case that younger adolescents engage in violence more purposefully and less impulsively due to a need to establish status or as part of socialization by older teenagers (e.g., Canada, 1995). By the later teenaged years, though, self-control is the stronger predictor, perhaps because those with higher AED have learned “the code of the street” (Anderson, 1999), resulting in greater comfort with spontaneous use of violence.²⁶ Future research should examine the influence of peers within the life history framework. Another possibility is that self-control is not a stable trait, as Gottfredson and Hirschi (1990) posit. The fact that self-control is measured only at wave 10 in the RYDS, when subjects are about 20 years old, may explain the strengthened relationship between self-control and risky behaviors as subjects age – it may be simply that the relationship strengthens as the temporal distance between the variables diminishes.

AED and gang membership.

In Chapter 6, I examine the effects of the latent measures of AED on individuals’ prevalence, duration, and stability of gang membership in the RYDS data. In the full-sample structural models, AED predicts gang membership only in the first two models, when AED is measured at around ages 14.5 to 15 (Table 6.1). The influence of low self-control on gang membership remains strong and significant throughout adolescence, though. Additionally, AED significantly affects gang membership indirectly through low self-control in all of the models. Taken together, the results indicate that AED does impact whether one reports gang membership in mid-adolescence, but in later adolescence, low self-control has more influence.

²⁶ For example, in saying, “I remember clearly the time in my life that I knew nothing of violence and how hard I worked later to learn to become capable of it,” Canada (1995, p. 23) exemplifies the street socialization process.

The sex-separated structural models reveal some interesting differences (Table 6.2). These findings show that AED affects gang membership for both sexes in the earlier waves, but self-control mediates this relationship, particularly for females. It appears that AED is strongly linked to low self-control for females, and low self-control is what predicts gang membership. This finding is expected within the life history theoretical framework – AED does not directly correspond to gang membership for females, perhaps because gang involvement is unlikely to improve a young woman’s chances of finding a desirable childrearing partner.

To study the relationship between AED and length of time in the gang, I estimate a negative binomial regression because most RYDS participants spend a short period of time in the gang, if they are gang-involved at all. Of the variables in the model, only low self-control significantly predicts gang duration (Table 6.3). It is likely that AED contributes to the length of time one spends in a gang, but its effect is mediated by self-control. Discounting the future results in gang activity for those who also have difficulty with impulse and temper control. This is further supported below, in the last regression model.

Finally, I study the relationships between AED, low self-control, and stability of gang membership. The multinomial logistic regression reveals that youths in all three categories of gang members – that is, short-term, intermittent, and long-term gang members – are significantly more likely to have low self-control than their nongang peers (Table 6.4). Short- and long-term gang members are also more likely to anticipate an early death. The most intriguing finding in this analysis is the discovery that intermittent gang members do not significantly differ from nongang youth in terms of AED, but low self-control substantially influences intermittency of gang membership, more so than short- or long-term gang involvement.

In both the structural models predicting gang membership and the negative binomial model predicting length of time in the gang, I find that although AED affects gang membership and duration, its effect is mediated by low self-control, which exerts a stronger influence on both of these dependent variables than does AED. Upon exploring the stability of gang membership, though, I find that low self-control is a stronger predictor of intermittent gang membership specifically. Conversely, AED exerts a stronger influence on both short- and long-term gang membership patterns, compared to self-control. This finding likely results from the fact that intermittent gang members actually report more waves of gang involvement than the long-term members do. The findings further suggest a difference between AED and low self-control. Those who have high levels of AED join the gang for one period (i.e., short- and long-term gang members), then desist permanently. Intermittent gang members do not differ from nongang youth in terms of AED. However, low self-control corresponds much more to intermittent gang membership than to any other gang stability category. It seems that those who have trouble controlling their impulses and their tempers are more likely to enter and exit a gang numerous times, rather than leave the group for good after one period of experimentation.

Causal ordering of AED and risk-taking behavior.

In Chapter 7, I estimate autoregressive cross-lagged panel models with the RYDS data in an attempt to determine whether AED causes risk-taking behaviors, or if the reverse is true. Previous research found reciprocal effects between AED and risky health behaviors – AED predicted later risky health behaviors and vice versa (Borowsky et al., 2009). A key benefit of the RYDS data is the large number of waves of data, collected from a sample of at-risk youth at six-month intervals throughout the teen years. The use of many waves of data, especially collected so close in time, allows for a better understanding of how AED and risky behaviors -

change and influence each other over time. An autoregressive cross-lagged panel model measures the effect of one construct on another measured at a later time, accounting for previous levels of the dependent variable as well as the correlation between the two constructs at the first observation period (Selig & Little, 2012).

The results of the panel models estimated in Chapter 7 enhance the complexity of the relationship between AED and risk-taking behavior. Although the two-wave structural models estimated in Chapters 5 and 6 generally show significant effects of AED on violence and gang membership six months later, the cross-lagged models do not consistently produce the same conclusions. This might be partially due to the fact that involvement in violence and gang membership declines steeply after wave 2, resulting in more stable relationships across the later waves but less apparent stability in the earlier waves. A limitation of autoregressive models is that they do not describe within-person stability, so a large autoregressive coefficient can indicate several different things (Selig & Little, 2012). Here, it appears that the stability coefficients for risk-taking behaviors indicate a drop in the behavior from waves 2 to 3, but little or no change over time in the later waves. Another potential explanation for the discrepancies between the two-wave SEMs (Chapters 5 and 6) and the autoregressive cross-lagged models (Chapter 7) is that the effects seen in Chapters 5 and 6, in models with shorter timeframes and without an autoregressive component, result from an earlier correlation between AED and the risk-taking variables. When the panel models control for these correlations, the cross-lagged effects vanish, for the most part.

The male-only panel model of AED and gang membership (Figure 7.4) is an exception to this finding; AED predicts gang membership six months later, from waves 2 to 3 and 3 to 4. Gang membership does not predict AED. The male-only panel model of AED and gang

membership is also the best fit for the data, with fit statistics substantially better than those for all of the other models. This indicates that for males, AED is a causal factor in gang membership, even after controlling for the correlation between AED and gang membership.

Implications

The previous section gave an overview of the dissertation's findings. Here, I highlight key findings and consider their implications for research and practice.

Criminal justice agencies' strategies to reduce violence and gang activity often emphasize deterrence from criminal behavior. These policies rely on the logic that the threat of harsh punishment discourages individuals from crime. However, such strategies will fail if individuals do not fear these consequences. This may occur when one feels that he or she has nothing to lose and/or no future to look forward to. Many youths embody this "live fast, die young" mentality, particularly those already at risk of delinquency due to other risk factors. For years, qualitative studies have suggested that many delinquent adolescents possess fatalistic attitudes, and that such beliefs are significantly related to outcomes such as drug use and offending (Anderson, 1999; Hoffman, 2004; Tolleson, 1997). Despite the indication that AED is a crucial correlate of delinquent activity, only recently have criminologists begun to directly examine this concept.

Given the numerous deleterious effects of AED, several researchers have suggested that pediatricians, social workers, and others who work with children ask about perceived risk of death to improve health outcomes and increase chances of effective prevention of risky behaviors (Borowsky et al., 2009; Duke, Borowsky, et al., 2011; Jamieson & Romer, 2008; Nguyen et al., 2012). The findings of this study may benefit practitioners who can use this research to create a youth AED risk assessment instrument. For example, a risk assessment worksheet that assigns points for characteristics that predict AED (low self-esteem, depression,

low attachment to parents, etc.) can help school employees, doctors, community supervision and corrections officers, and others who work with at-risk youth identify those most likely to anticipate an early death. Of course, the simplest way to identify these individuals is to ask them when they believe they will die. A risk assessment instrument, however, would permit practitioners to avoid asking such an uncomfortable question while also illuminating *why* the youth harbors a fatalistic attitude, allowing for personalized interventions. Furthermore, such an instrument could enable practitioners to screen for young children at risk of AED but who may not yet express fatalistic attitudes.

It is beyond the scope of this dissertation to prescribe specific policies or programs that will effectively reduce AED and delinquency. However, the finding that low self-esteem, depression, low attachment to parents, and poor connection with school are all strongly related to AED in both the Add Health and RYDS samples indicates that in order to reduce or prevent AED in individuals, these factors must be addressed. Low self-esteem has the strongest relationship with the AED factor variables by far, followed closely by depression. Efforts to enhance self-esteem and lower depression should help in reducing AED in children by giving them a stronger sense of control over their lives and more hope for the future.

Low attachment to parents and connection with school are the other two strongly related factors in all of the measurement models. Other research shows that these variables are also strongly and independently related to delinquency (Thornberry, Lizotte, Krohn, Farnworth, & Jang, 1991). Strengthening child-parent attachment and enhancing students' sense of connection with their schools should reduce both AED and delinquency by improving the youth's bond to society, investment in conventional values, and aspirations for achievement.

Although the variables measuring negative neighborhood environment do not strongly relate to AED here, others' research indicates that more research on ecological factors and AED is warranted. The lack of consistent findings here is surprising given the extensive literature on communities' effects on young residents' AED. However, my findings do not suggest that neighborhood does *not* influence AED. For one thing, the item measuring whether a respondent lives in an unsafe neighborhood does load in the Add Health Wave I model, with a loading of .33. In the Wave II model, that loading is .29 – just short of the .30 cutoff value. In the RYDS models, the neighborhood factor variable comprises the adolescents' parents' responses. Parents may not feel the same way about the community as their children do; this might be why the measure fails to load onto the AED factor variable. Other measures more directly related to mortality, such as neighborhood life expectancy or frequency of funerals or violent incidents like drive-by shootings, may show a stronger relationship with AED and should receive consideration in future research.

Another conclusion to draw from these findings is that prevention and interventions should be implemented when adolescents are young – at least younger than 14 years old. The RYDS data show that adolescents are most likely to engage in violence and gang activity when they are younger than 15, and the likelihood of such delinquency declines with age. Perhaps adolescents are compelled to engage in these behaviors in the early teenaged years in order to establish status by manifesting nerve and proving themselves. Once a youth has accomplished this goal, violence is less necessary and appears to be more the result of poor impulse control and less a purposeful performance. Similarly, the gang may have more appeal for younger children who have yet to hit puberty and are at the mercy of larger, older adolescents. Conversely, for those larger, older adolescents, the gang may hold less appeal than it did when they were

younger because they have less need of protection, having grown and had opportunities to prove themselves.

As adolescents age, low self-control (as measured primarily by questions about impulsivity and temper) becomes a stronger predictor of violent delinquency. Low self-control predicts longer gang involvement and intermittent gang membership in particular, indicating that youths with low self-control are more likely to enter and leave gangs repeatedly throughout adolescence. If Gottfredson and Hirschi are incorrect and low self-control is not set by age 10, interventions to promote self-control could prove helpful in reducing engagement in violence and gangs. Neurological research shows that individuals do not fully develop the regions of the brain that process control until adulthood. More research is needed to determine whether and how self-control can be manipulated, taking into consideration neurological development and constraints.

Limitations and Future Research

Although this dissertation offers several contributions regarding measurement of AED and its relationships with self-control, violence, gang involvement, and sexual behaviors, a number of questions remain unanswered.

Theory.

One glaring limitation in the application of life history theory to criminal behavior is that it fails to account for risk-taking by people who might not be driven by reproductive urges. For example, it seems unlikely that people who are homosexual, asexual, or unable to reproduce would engage in risk-taking behaviors with the aim of achieving reproduction, and yet such people do engage in risky behaviors and crime. I have found nothing in the life history theory literature to explain why people who cannot or do not want to reproduce would engage in risky behaviors. Because the drive to multiply is so essential to a species' survival, perhaps the urges

to behave in ways that maximize reproduction are coded into each organism's DNA. If this is the case, then sexual orientation and ability have no bearing on the relationship between AED and risk-taking behavior. However, due to the lack of research on this topic, I can speculate no further as to whether the relationship between AED and risky behavior differs according to sexual identity or ability. Due to data limitations I cannot explore differences in AED and risk-taking behaviors by sexual orientation in the dissertation.²⁷ Future research investigating risk-taking behavior among those who cannot or do not wish to reproduce would greatly benefit the utility and applicability of life history theory.

Another key area in which life history theory would benefit from more research is in decision-making processes. Life history theory makes no claims about conscious decision-making; evolutionary biology requires no such claims. However, within developmental psychology and related fields, analysis of rationality and decision-making processes would help to illuminate the interplay between AED and risk-taking behaviors. For example, in Chapter 6 I find that higher levels of AED and low self-control are significantly associated with both short- and long-term gang membership, compared to nongang youth. The coefficients for these two stability categories are similar in terms of direction, significance, and magnitude, but AED might play different roles for these groups. Those who do not foresee a long future may join a gang for protection (i.e., to improve their chances of survival) or because they feel they have nothing to

²⁷ The Add Health interviews simply asked respondents if they had "had a romantic attraction" to males and to females, without any clarification of what this means. In the RYDS data, respondents were asked at waves 10 through 12 (ages 21 to 23), "At this point in life, would you describe your primary sexual preference or identity as: heterosexual or straight; gay or lesbian; bisexual; uncertain?" Three respondents identified as gay or lesbian at least once. Of the two respondents who identified as gay/lesbian at all three waves, neither reported any violence or gang membership. The third person first identified as straight, then gay, then bisexual. This person reported violent behavior during two waves, but no gang involvement. Beyond these basic descriptive statistics, I cannot explore the relationship between AED, risky behavior, and sexual behavior among non-heterosexual individuals due to the extremely small sample size.

lose and gang involvement might be fun. On the other hand, AED could drive either desistance from gang activity (logically, exposure to violence should encourage one to avoid that environment) or sustained gang involvement (if one feels no sense of control over what happens). To clarify these relationships, future research should probe youths about their decision-making processes.

Measurement.

This dissertation undertakes a great effort to create a valid and reliable measure of AED in the RYDS data. I use the Add Health data to guide the measurement process because Add Health directly measures AED; comparison of the AED latent variable with the direct measure allows for confirmation that the latent construct measures AED. While this method bolsters my confidence in the measurement of AED, it necessarily has several limitations.

Most importantly, I limit the factor analyses to concepts that both datasets measure comparably. This excludes several variables that likely relate to AED, such as violent victimization and neighborhood mortality rate. Inclusion of such measures would probably improve the AED construct's validity and strengthen its ability to predict risk-taking behaviors.

The advantage to using simple models, as I do here, is comparability between the Add Health and RYDS samples. This is crucial, given my goal of creating latent measures of AED in two separate data sources. The drawback to the simplicity of the models is that other important covariates are omitted from the analysis. For example, a great deal of research demonstrates that delinquency of one's peers strongly predicts one's own delinquency (Kissner & Pyrooz, 2009; Pratt & Cullen, 2000; Thornberry et al., 2003). Such a measure is not included here for three reasons. First, the Add Health data do not contain peer delinquency measures, and one of my primary goals in creating the AED proxy measures and estimating the structural models is

resemblance between the two datasets. Second, consideration of a peer effect falls outside the scope of this project. Third, I found no evidence of a link between AED and peer delinquency in the literature. Although one might exist, it's more probable that a fatalistic attitude is influenced by the victimization experienced by one's friends, rather than their offending (although the two may be closely related). Given the lack of research regarding peer effects on AED, future work should probe this potential relationship, especially with regard to risk-taking behaviors and violence in particular.

Although this dissertation takes a step toward establishing the causal ordering of AED and risk-taking behaviors, the findings are inconclusive. The results of the autoregressive cross-lagged panel models estimated in Chapter 7 add to the complexity of the relationship between AED and risk-taking behavior. Though the two-wave structural models estimated in Chapters 5 and 6 generally show significant direct and/or indirect effects of AED on violence and gang membership six months later, the cross-lagged models do not. There are two possible explanations for this inconsistency. One possibility is that the effects seen before, in models with shorter timeframes and without autoregressive components, result from an earlier correlation between AED and the risk-taking variables. When the panel models control for these correlations, the cross-lagged effects vanish (for the most part). Another explanation is that there is too much instability in the risky behaviors across the full observation period for the autoregressive models to accurately model the data. The RYDS subjects tend to report violence and gang membership at higher levels in the earlier waves, with steep drop-offs in these behaviors at waves 3 and 4.

To better evaluate the causal relationships between AED and risk-taking behaviors throughout adolescence, future research should estimate autoregressive cross-lagged panel

models with younger participants. This will facilitate identification of the point at which AED develops in children, most likely prior to any engagement in serious violent activity, according to life history theory. Beginning a panel model at an age when AED and delinquency do not correlate with each other will improve the likelihood that clearer causal relationships between AED and risky behaviors will emerge.

Conclusion

Few things scare us more than death, and people who believe that their time is running out will resort to desperate measures if they have nothing to lose. Within the framework of life history theory, this means that individuals will accelerate their life histories and put themselves in harm's way if it improves their chances of reproductive success. Adolescent males who fast-track their life histories typically engage in risky behaviors, sometimes including violent offending. This violence is driven in part by competition with other young men in pursuit of mating opportunities. Even the ultimate risk – death – may not deter violence for those who already believe their days are numbered. Expanding our understanding of AED and its relationship with risk-taking behavior is crucial; greater knowledge about the causes and consequences of AED will aid in delinquency prevention and intervention efforts.

References

- Akers, R. L. (1991). Self-control as a general theory of crime. *Journal of Quantitative Criminology*, 7(2), 201–212.
- Alexander, R. D. (1979). *Darwinism and human affairs*. Seattle, WA: University of Washington Press.
- Allison, P. D. (2003). Missing data techniques for structural equation modeling. *Journal of Abnormal Psychology*, 112(4), 545–557. <http://doi.org/10.1037/0021-843X.112.4.545>
- Anderson, E. (1999). *Code of the street: Decency, violence, and the moral life of the inner city*. New York, NY: W. W. Norton & Company, Inc.
- Arias, E. (2014). United States life tables, 2010. In *National Vital Statistics Reports; Volume 63, Number 7* (Vol. 63). Hyattsville, MD: National Center for Health Statistics. Retrieved from http://www.cdc.gov/nchs/data/nvsr/nvsr58/nvsr58_10.pdf
- Asparouhov, T., & Muthén, B. O. (2010). *Weighted least squares estimation with missing data. Mplus Technical Appendix*. Retrieved from <http://www.statmodel.com/download/GstrucMissingRevision.pdf>
- Bell, F. C., & Miller, M. L. (2005). Life tables for the United States Social Security Area 1900-2100: Actuarial study no. 120. Retrieved from http://www.ssa.gov/OACT/NOTES/as120/LifeTables_Body.html
- Bickel, W. K., Yi, R., Kowal, B. P., & Gatchalian, K. M. (2008). Cigarette smokers discount past and future rewards symmetrically and more than controls: Is discounting a measure of impulsivity? *Drug and Alcohol Dependence*, 96(3), 256–262. <http://doi.org/10.1016/j.drugalcdep.2008.03.009>

- Blakemore, S.-J., & Robbins, T. W. (2012). Decision-making in the adolescent brain. *Nature Neuroscience*, *15*(9), 1184–1191. <http://doi.org/10.1038/nn.3177>
- Bolland, J. M., Lian, B. E., & Formichella, C. M. (2005). The origins of hopelessness among inner-city African-American adolescents. *American Journal of Community Psychology*, *36*(3-4), 293–305. <http://doi.org/10.1007/s10464-005-8627-x>
- Borowsky, I. W., Ireland, M., & Resnick, M. D. (2009). Health status and behavioral outcomes for youth who anticipate a high likelihood of early death. *Pediatrics*, *124*(1), e81–e88. <http://doi.org/10.1542/peds.2008-3425>
- Brezina, T., Tekin, E., & Topalli, V. (2009). “Might not be a tomorrow”: A multimethods approach to anticipated early death and youth crime. *Criminology*, *47*(4), 1091–1129. <http://doi.org/10.1111/j.1745-9125.2009.00170.x>
- Burt, C. H., & Simons, R. L. (2013). Self-control, thrill seeking, and crime: Motivation matters. *Criminal Justice and Behavior*, *40*(11), 1326–1348. <http://doi.org/10.1177/0093854813485575>
- Caldwell, R. M., Wiebe, R. P., & Cleveland, H. H. (2006). The influence of future certainty and contextual factors on delinquent behavior and school adjustment among African American adolescents. *Journal of Youth and Adolescence*, *35*(4), 591–602. <http://doi.org/10.1007/s10964-006-9031-z>
- Canada, G. (1995). *Fist stick knife gun: A personal history of violence in America*. Boston, MA: Beacon Press.
- Casey, B. J., & Caudle, K. (2013). The teenage brain: Self control. *Current Directions in Psychological Science*, *22*(2), 82–87. <http://doi.org/10.1177/0963721413480170>
- Centers for Disease Control and Prevention. (2012). Deaths, percent of total deaths, and death

- rates for the 15 leading causes of death in 10-year age groups, by race and sex: United States, 1999-2010. Retrieved from http://www.cdc.gov/nchs/data/dvs/LCWK2_2010.pdf
- Clarke, D. (2004). Neuroticism: Moderator or mediator in the relation between locus of control and depression? *Personality and Individual Differences, 37*(2), 245–258.
<http://doi.org/10.1016/j.paid.2003.08.015>
- Copping, L. T., Campbell, A., & Muncer, S. (2014). Conceptualizing time preference: A life-history analysis. *Evolutionary Psychology, 12*(4), 829–847.
- Cortina, J. M. (1993). What is coefficient alpha? An examination of theory and applications. *Journal of Applied Psychology, 78*(1), 98–104. <http://doi.org/10.1037//0021-9010.78.1.98>
- Courtwright, D. T. (1998). *Violent land: Single men and social disorder from the frontier to the inner city*. Cambridge, MA: Harvard University Press.
- Curry, G. D., Decker, S. H., & Egley Jr., A. (2002). Gang involvement and delinquency in a middle school population. *Justice Quarterly, 19*(2), 275–292.
<http://doi.org/10.1080/07418820200095241>
- Daly, M., & Wilson, M. (2005). Carpe diem: Adaptation and devaluing the future. *The Quarterly Review of Biology, 80*(1), 55–60. http://doi.org/10.1163/_afco_asc_2291
- Decker, S. H., & Lauritsen, J. L. (2002). Leaving the gang. In C. R. Huff (Ed.), *Gangs in America III* (pp. 51–67). Thousand Oaks, CA: Sage Publications.
- Decker, S. H., & Van Winkle, B. (1996). *Life in the gang: Family, friends, and violence*. New York, NY: Cambridge University Press.
- Deschenes, E. P., & Esbensen, F.-A. (1999). Violence and gangs: Gender differences in perceptions and behavior. *Journal of Quantitative Criminology, 15*(1), 63–96.
- Duke, N. N., Borowsky, I. W., Pettingell, S. L., Skay, C. L., & McMorris, B. J. (2011).

- Adolescent early death perception: Links to behavioral and life outcomes in young adulthood. *Journal of Pediatric Health Care*, 25(4), 224–234.
<http://doi.org/10.1016/j.pedhc.2010.03.004>
- Duke, N. N., Skay, C. L., Pettingell, S. L., & Borowsky, I. W. (2009). Adolescent perception of premature risk for death: Contributions from individual and environmental contextual factors. *Academic Pediatrics*, 9(4), 256–262. <http://doi.org/10.1016/j.acap.2009.02.004>
- Duke, N. N., Skay, C. L., Pettingell, S. L., & Borowsky, I. W. (2011). Early death perception in adolescence: Identifying factors associated with change from pessimism to optimism about life expectancy. *Clinical Pediatrics*, 50(1), 21–28.
<http://doi.org/10.1177/0009922810379041>
- DuRant, R. H., Cadenhead, C., Pendergrast, R. A., Slavens, G., & Linder, C. W. (1994). Factors associated with the use of violence among urban black adolescents. *American Journal of Public Health*, 84(4), 612–617. <http://doi.org/10.2105/AJPH.84.4.612>
- Ellis, B. J., Del Giudice, M., Dishion, T. J., Figueredo, A. J., Gray, P., Griskevicius, V., ... Wilson, D. S. (2012). The evolutionary basis of risky adolescent behavior: Implications for science, policy, and practice. *Developmental Psychology*, 48(3), 598–623.
<http://doi.org/10.1037/a0026220>
- Esbensen, F.-A., Peterson, D., Taylor, T. J., & Freng, A. (2009). Similarities and differences in risk factors for violent offending and gang membership. *The Australian and New Zealand Journal of Criminology*, 42(3), 310–335. <http://doi.org/10.1375/acri.42.3.310>
- Fagan, J., & Wilkinson, D. L. (1998). Guns, youth violence, and social identity in inner cities. *Crime and Justice*, 24, 105–188.
- Figueredo, A. J., Vasquez, G., Brumbach, B. H., Schneider, S. M. R., Sefcek, J. A., Tal, I. R., ...

- Jacobs, W. J. (2006). Consilience and life history theory: From genes to brain to reproductive strategy. *Developmental Review, 26*(2), 243–275.
<http://doi.org/10.1016/j.dr.2006.02.002>
- Fischhoff, B., Parker, A. M., Bruine de Bruin, W., Downs, J., Palmgren, C., Dawes, R., & Manski, C. F. (2000). Teen expectations for significant life events. *Public Opinion Quarterly, 64*(2), 189–205. <http://doi.org/10.1086/317762>
- Frankenhuis, W. E., Panchanathan, K., & Nettle, D. (2016). Cognition in harsh and unpredictable environments. *Current Opinion in Psychology, 7*, 76–80.
<http://doi.org/10.1016/j.copsyc.2015.08.011>
- Gallup, A. C., O'Brien, D. T., & Wilson, D. S. (2011). Intrasexual peer aggression and dating behavior during adolescence: An evolutionary perspective. *Aggressive Behavior, 37*(3), 258–267. <http://doi.org/10.1002/ab.20384>
- Garbarino, J., Kostelny, K., & Dubrow, N. (1991). *No place to be a child*. Lexington, MA: Lexington Books.
- Geis, G. (2000). On the absence of self-control as the basis for a general theory of crime: A critique. *Theoretical Criminology, 4*(1), 35–53.
<http://doi.org/10.1177/1362480600004001002>
- Giedd, J. N., Blumenthal, J., Jeffries, N. O., Castellanos, F. X., Liu, H., Zijdenbos, A., ... Rapoport, J. L. (1999). Brain development during childhood and adolescence: A longitudinal MRI study. *Nature Neuroscience, 2*(10), 861–863.
<http://doi.org/10.1038/13158>
- Gottfredson, M. R., & Hirschi, T. (1990). *A general theory of crime*. Palo Alto, CA: Stanford University Press.

- Graham, J. W. (2009). Missing data analysis: Making it work in the real world. *Annual Review of Psychology*, 60, 549–576. <http://doi.org/10.1146/annurev.psych.58.110405.085530>
- Griskevicius, V., Tybur, J. M., Gangestad, S. W., Perea, E. F., Shapiro, J. R., & Kenrick, D. T. (2009). Aggress to impress: Hostility as an evolved context-dependent strategy. *Journal of Personality and Social Psychology*, 96(5), 980–994. <http://doi.org/10.1037/a0013907>
- Harris, G. T., Rice, M. E., Hilton, N. Z., Lalumière, M. L., & Quinsey, V. L. (2007). Coercive and precocious sexuality as a fundamental aspect of psychopathy. *Journal of Personality Disorders*, 21(1), 1–27. <http://doi.org/10.1521/pedi.2007.21.1.1>
- Harris, K. M. (2011). *Design features of Add Health*. Chapel Hill: Carolina Population Center, University of North Carolina at Chapel Hill. Retrieved from <http://www.cpc.unc.edu/projects/addhealth/data/guides>
- Hill, E. M., Ross, L. T., & Low, B. S. (1997). The role of future unpredictability in human risk-taking. *Human Nature*, 8(4), 287–325. <http://doi.org/10.1007/BF02913037>
- Hoffman, J. S. (2004). *Youth violence, resilience, and rehabilitation*. New York, NY: LFB Scholarly Publishing LLC.
- Hooper, D., Coughlan, J., & Mullen, M. (2008). Structural equation modelling: Guidelines for determining model fit. *The Electronic Journal of Business Research Methods*, 6(1), 53–60.
- Hope, T. L., & Chapple, C. L. (2004). Maternal characteristics, parenting, and adolescent sexual behavior: The role of self-control. *Deviant Behavior*, 26(1), 25–45. <http://doi.org/10.1080/016396290500405>
- Hope, T. L., & Damphousse, K. R. (2002). Applying self-control theory to gang membership in a non-urban setting. *Journal of Gang Research*, 9(2), 41–61.

- Hughes, L. A., & Short Jr., J. F. (2005). Disputes involving youth street gang members: Micro-social contexts. *Criminology*, *43*(1), 43–76.
- Hurd, M. D., & McGarry, K. (1995). Evaluation of the subjective probabilities of survival in the health and retirement study. *The Journal of Human Resources*, *30*, S268–S292.
<http://doi.org/10.2307/146285>
- Iacobucci, D. (2010). Structural equations modeling: Fit indices, sample size, and advanced topics. *Journal of Consumer Psychology*, *20*, 90–98.
<http://doi.org/10.1016/j.jcps.2009.09.003>
- Jamieson, P. E., & Romer, D. (2008). Unrealistic fatalism in U.S. youth ages 14 to 22: Prevalence and characteristics. *Journal of Adolescent Health*, *42*(2), 154–160.
<http://doi.org/10.1016/j.jadohealth.2007.07.010>
- Kissner, J., & Pyrooz, D. C. (2009). Self-control, differential association, and gang membership: A theoretical and empirical extension of the literature. *Journal of Criminal Justice*, *37*(5), 478–487. <http://doi.org/10.1016/j.jcrimjus.2009.07.008>
- Klein, M. W. (1995). *The American street gang: Its nature, prevalence, and control*. New York, NY: Oxford University Press.
- Kolenikov, S. (n.d.). Polychoric: The polychoric correlation package. Retrieved October 1, 2014, from <http://web.missouri.edu/~kolenikovs/stata>
- Kotlowitz, A. (1991). *There are no children here: The story of two boys growing up in the other America*. New York, NY: Doubleday.
- Krohn, M. D., & Thornberry, T. P. (1999). Retention of minority populations in panel studies of drug use. *Drugs and Society*, *14*, 185–207. http://doi.org/10.1300/J023v14n01_14
- LaGrange, T. C., & Silverman, R. A. (1999). Low self-control and opportunity: Testing the

- general theory of crime as an explanation for gender differences in delinquency. *Criminology*, 37(1), 41–72. <http://doi.org/10.1111/j.1745-9125.1999.tb00479.x>
- Loftin, C. (1986). Assaultive violence as a contagious social process. *Bulletin of the New York Academy of Medicine*, 62(5), 550–555.
- Lorion, R. P., & Saltzman, W. (1993). Children’s exposure to community violence: Following a path from concern to research to action. *Psychiatry*, 56, 55–65. <http://doi.org/10.1521/00332747.1993.11024621>
- Melde, C., & Esbensen, F.-A. (2013). Gangs and violence: Disentangling the impact of gang membership on the level and nature of offending. *Journal of Quantitative Criminology*, 29(2), 143–166. <http://doi.org/10.1007/s10940-012-9164-z>
- Mishra, S., & Lalumière, M. L. (2011). Individual differences in risk-propensity: Associations between personality and behavioral measures of risk. *Personality and Individual Differences*, 50(6), 869–873. <http://doi.org/10.1016/j.paid.2010.11.037>
- Murphy, S. L., Xu, J., & Kochanek, K. D. (2013). Deaths: Final data for 2010. In *National Vital Statistics Reports; vol 61 no 4* (Vol. 61). Hyattsville, MD: National Center for Health Statistics.
- Muthén, B. O., du Toit, S. H. C., & Spisic, D. (1997). *Robust inference using weighted least squares and quadratic estimating equations in latent variable modeling with categorical and continuous outcomes [technical report]*. Retrieved from http://pages.gseis.ucla.edu/faculty/muthen/articles/Article_075.pdf
- Muthén, L. K., & Muthén, B. O. (2007). *Mplus (Version 5) [Software]*. Los Angeles, CA: Muthén & Muthén.
- Muthén, L. K., & Muthén, B. O. (2012). *Mplus user’s guide* (7th ed.). Los Angeles, CA: Muthén

& Muthén.

Nguyen, Q. C., Hussey, J. M., Halpern, C. T., Villaveces, A., Marshall, S. W., Siddiqi, A., & Poole, C. (2012). Adolescent expectations of early death predict young adult socioeconomic status. *Social Science & Medicine*, *74*(9), 1452–1460.
<http://doi.org/10.1016/j.socscimed.2012.01.006>

Palmer, C. T., & Tilley, C. F. (1995). Sexual access to females as a motivation for joining gangs: An evolutionary approach. *Journal of Sex Research*, *32*(3), 213–217.
<http://doi.org/10.1080/00224499509551792>

Paternoster, R., Brame, R., Mazerolle, P., & Piquero, A. (1998). Using the correct statistical test for the equality of regression coefficients. *Criminology*, *36*(4), 859–866.

Pellegrini, A. D., & Long, J. D. (2003). A sexual selection theory longitudinal analysis of sexual segregation and integration in early adolescence. *Journal of Experimental Child Psychology*, *85*(3), 257–278. [http://doi.org/10.1016/S0022-0965\(03\)00060-2](http://doi.org/10.1016/S0022-0965(03)00060-2)

Perrone, D., Sullivan, C. J., Pratt, T. C., & Margaryan, S. (2004). Parental efficacy, self-control, and delinquency: A test of a general theory of crime on a nationally representative sample of youth. *International Journal of Offender Therapy and Comparative Criminology*, *48*(3), 298–312. <http://doi.org/10.1177/0306624X03262513>

Peterson, D., Taylor, T. J., & Esbensen, F.-A. (2004). Gang membership and violent victimization. *Justice Quarterly*, *21*(4), 793–815.
<http://doi.org/10.1080/07418820400095991>

Piquero, A. R. (2016). “Take my license n’ all that jive, I can’t see ... 35”: Little hope for the future encourages offending over time. *Justice Quarterly*, *33*(1), 73–99.
<http://doi.org/10.1080/07418825.2014.896396>

- Pratt, T. C., & Cullen, F. T. (2000). The empirical status of Gottfredson and Hirschi's general theory of crime: A meta-analysis. *Criminology*, 38(3), 931–964.
- Pyrooz, D. C., Decker, S. H., & Webb, V. J. (2014). The ties that bind: Desistance from gangs. *Crime & Delinquency*, 60(4), 491–516. <http://doi.org/10.1177/0011128710372191>
- Rotter, J. B. (1966). Generalized expectancies for internal versus external control of reinforcement. *Psychological Monographs: General and Applied*, 80(1), 1–28. <http://doi.org/10.1037/h0092976>
- Rummel, R. J. (1967). Understanding factor analysis. *The Journal of Conflict Resolution*, 11(4), 444–480. <http://doi.org/10.1177/002200276701100405>
- SAS Institute Inc. (2010). *SAS software, Version 9 of the SAS System for Unix*. Cary, NC: SAS Institute Inc.
- Schumacker, R. E., & Lomax, R. G. (2010). *A Beginner's Guide to Structural Equation Modeling* (3rd ed.). New York, NY: Routledge.
- Selig, J. P., & Little, T. D. (2012). Autoregressive and cross-lagged panel analysis for longitudinal data. In B. Laursen, T. D. Little, & N. A. Card (Eds.), *Handbook of Developmental Research Methods* (pp. 265–278). New York, NY: The Guilford Press.
- Silberman, C. E. (1978). *Criminal violence, criminal justice*. New York, NY: Random House.
- Simpson, J. A., Griskevicius, V., Kuo, S. I.-C., Sung, S., & Collins, W. A. (2012). Evolution, stress, and sensitive periods: The influence of unpredictability in early versus late childhood on sex and risky behavior. *Developmental Psychology*, 48(3), 674–686. <http://doi.org/10.1037/a0027293>
- Swisher, R. R., & Warner, T. D. (2013). If they grow up: Exploring the neighborhood context of adolescent and young adult survival expectations. *Journal of Research on Adolescence*,

23(4), 678–694. <http://doi.org/10.1111/jora.12027>

Sylwester, K., & Pawłowski, B. (2011). Daring to be darling: Attractiveness of risk takers as partners in long- and short-term sexual relationships. *Sex Roles, 64*(9), 695–706.

<http://doi.org/10.1007/s11199-010-9790-6>

Teplin, L. A., McClelland, G. M., Abram, K. M., & Mileusnic, D. (2005). Early violent death among delinquent youth: A prospective longitudinal study. *Pediatrics, 115*(6), 1586–

1593. <http://doi.org/10.1542/peds.2004-1459>

Thornberry, T. P., Krohn, M. D., Lizotte, A. J., Smith, C. A., & Tobin, K. (2003). *Gangs and delinquency in developmental perspective*. New York, NY: Cambridge University Press.

Thornberry, T. P., Lizotte, A. J., Krohn, M. D., Farnworth, M., & Jang, S. J. (1991). Testing interactional theory: An examination of reciprocal causal relationships among family, school, and delinquency. *The Journal of Criminal Law & Criminology, 82*(1), 3–35.

<http://doi.org/10.2307/1143788>

Tillyer, M. S. (2015). Victimization, offending, and perceived risk for early violent death. *Criminal Justice and Behavior, 42*(5), 529–545.

<http://doi.org/10.1177/0093854814554447>

Tolleson, J. (1997). The reparative power of violence in the lives of young black inner city gang members. *Smith College Studies in Social Work, 67*(3), 415–431.

<http://doi.org/10.1080/00377319709517500>

Twenge, J. M., Zhang, L., & Im, C. (2004). It's beyond my control: A cross-temporal meta-analysis of increasing externality in locus of control, 1960-2002. *Personality and Social Psychology Review, 8*(3), 308–319. http://doi.org/10.1207/s15327957pspr0803_5

Weston, R., & Gore Jr., P. A. (2006). A brief guide to structural equation modeling. *The*

- Counseling Psychologist*, 34(5), 719–751. <http://doi.org/10.1177/0011000006286345>
- Wiebe, R. P. (2012). Integrating criminology through adaptive strategy and life history theory. *Journal of Contemporary Criminal Justice*, 28(3), 346–365. <http://doi.org/10.1177/1043986212450231>
- Wilson, M., & Daly, M. (1985). Competitiveness, risk taking, and violence: The young male syndrome. *Ethology and Sociobiology*, 6(1), 59–73. [http://doi.org/10.1016/0162-3095\(85\)90041-X](http://doi.org/10.1016/0162-3095(85)90041-X)
- Wilson, M., & Daly, M. (1997). Life expectancy, economic inequality, homicide, and reproductive timing in Chicago neighbourhoods. *British Medical Journal*, 314(7089), 1271–1274. <http://doi.org/10.1136/bmj.314.7089.1271>
- Wilson, M., & Daly, M. (2006). Are juvenile offenders extreme future discounters? *Psychological Science*, 17(11), 989–994. <http://doi.org/10.1111/j.1467-9280.2006.01817.x>

Appendix A

Coding of Project Variables by Dataset

	Add Health Measurement	RYDS Measurement
First-Order Factor Analysis Measures		
Depression factor variable	<p>18 items. Examples: <i>How often was each of the following things true during the last week?</i></p> <ul style="list-style-type: none"> • You were bothered by things that don't usually bother you • You felt depressed • You thought your life had been a failure <p>0=never/rarely; 3=most/all the time Waves I, II</p>	<p>12 items. Examples: <i>Since we interviewed you last time, how often did you...</i></p> <ul style="list-style-type: none"> • Feel you had trouble keeping your mind on what you were doing • Feel depressed or very sad • Feel that you talked less than usual <p>1=never; 4=often Waves 2-8</p>
Low self-esteem factor variable	<p>6 items. Examples:</p> <ul style="list-style-type: none"> • You have a lot of good qualities • You have a lot to be proud of • You like yourself just the way you are <p>1=strongly agree; 5=strongly disagree Waves I, II</p>	<p>9 items. Examples:</p> <ul style="list-style-type: none"> • In general, you are satisfied with yourself • You feel that you have a number of good qualities • You can do things as well as most other people <p>1=strongly agree; 4=strongly disagree Waves 2-8</p>
Low attachment to parents factor variable	<p>4 items:</p> <ul style="list-style-type: none"> • How close do you feel to your [mother/father]? • How much do you think [he/she] cares about you? <p>1=very much; 5=not at all Waves I, II</p>	<p>11 items. Examples: <i>How often would you say that...</i></p> <ul style="list-style-type: none"> • You get along well with your [mother/father]? • You feel that you can really trust your [mother/father]? • You really enjoy your [mother/father]? <p>1=often; 4=never Waves 2-8</p>

	Add Health Measurement	RYDS Measurement
...Appendix A continued...		
Low school connection factor variable	4 items: <ul style="list-style-type: none"> You feel close to people at your school You feel like you are part of your school You are happy to be at your school How much do you want to go to college? 1=very much; 5=not at all Waves I, II	14 items. Examples: <ul style="list-style-type: none"> School is boring to you You don't really belong at school You don't care what teachers think of you 1=strongly disagree; 4=strongly agree Waves 2-8
Poor academic performance	Grade point average factor variable; 4 items. <i>At the most recent grading period, what was your grade in:</i> <ul style="list-style-type: none"> English or language arts Mathematics History or social studies Science 1=A; 4=D or lower Waves I, II	California Achievement Test percentile <ul style="list-style-type: none"> CAT total math percentile Percentile is reverse-coded so low-scoring individuals rate high on this measurement of poor academic performance Waves 2-8
Negative neighborhood	Unsafe neighborhood <ul style="list-style-type: none"> Do you usually feel safe in your neighborhood? 0=yes; 1=no Waves I, II	Neighborhood disorganization factor variable; 17 items. Examples: <i>Tell me if each thing is a problem in your neighborhood:</i> <ul style="list-style-type: none"> Syndicate, mafia, or organized crime Assaults and muggings Drug use or drug dealing in the open 1=not a problem; 3=a big problem Waves 2-8 (parent report)
Receipt of public assistance	0=not receiving public assistance; 1=receiving public assistance Waves I, II	0=does not receive public assistance; 1=parent receives public assistance Waves 2-7 (parent report)

	Add Health Measurement	RYDS Measurement
...Appendix A continued...		
Parent unemployment	0=not unemployed; 1=unemployed Wave I (parent report)	0=not unemployed; 1=unemployed Waves 2-8 (parent report)
Mediating Variable		
Low self-control factor variable	6 items. Examples: <i>Since school started this year, how often have you had trouble:</i> <ul style="list-style-type: none"> • Paying attention in school? • Getting your homework done? • Getting along with other students? 0=never; 4=almost every day Waves I-II	6 items. Examples: <ul style="list-style-type: none"> • You lose your temper pretty easily • Often when you're angry at people, you feel more like hurting them than talking to them about why you are angry • When you are really angry, other people better stay away from you 1=strongly disagree; 4=strongly agree Wave 10
Reproductive Variables		
Number of sexual partners	<ul style="list-style-type: none"> • With how many people, in total, including romantic relationship partners, have you ever had a sexual relationship? 0=0; 1=1-3; 2=4+ Waves I-III	<ul style="list-style-type: none"> • How many different people did you have sexual intercourse with since [date of last interview]? 0=0; 1=1-3; 2=4+ Waves 6-9
Been pregnant / impregnated someone	0=did not report pregnancy/getting someone pregnant; 1=reported pregnancy/getting someone pregnant Waves I-III	<ul style="list-style-type: none"> • Since [date of last interview], have you been pregnant/gotten a girl pregnant? 0=no; 1=yes Waves 5-9
Ever been pregnant/ impregnated someone	0=has never been pregnant or gotten someone pregnant; 1=has been pregnant or gotten someone pregnant Ever, up to Wave III	0=has never been pregnant or gotten someone pregnant; 1=has been pregnant or gotten someone pregnant Ever, up to wave 9

	Add Health Measurement	RYDS Measurement
...Appendix A continued...		
Dependent Variables		
Anticipated early death	Latent variable factor analyzed / Direct measure: <i>What do you think are the chances that:</i> <ul style="list-style-type: none"> You will live to age 35? (reversed) 1=almost no chance; 5=almost certain	N/A – latent variable only
Violence prevalence	<i>In the past 12 months, how often did you:</i> <ul style="list-style-type: none"> Use a weapon in a fight Get into a serious physical fight Take part in a fight where a group of your friends was against another group Use/threaten to use a weapon to get something from someone Physically force someone to have sexual intercourse against her will [males only] 0=no to all; 1=yes to one or more items Waves I, II	<i>Since we interviewed you last time, have you:</i> <ul style="list-style-type: none"> Attacked someone with a weapon or with the idea of seriously hurting or killing them Hit someone with the idea of hurting them Been involved in gang or posse fights Thrown objects such as rocks or bottles at people Used a weapon or force to make someone give you money or things Physically hurt or threatened to hurt someone to get them to have sex with you 0=no to all; 1=yes to one or more items Waves 2-9
Violence variety	N/A	Count of the types of violent acts one committed: <ul style="list-style-type: none"> Attacked someone with a weapon or with the idea of seriously hurting or killing them Hit someone with the idea of hurting them Been involved in gang or posse fights Thrown objects such as rocks or bottles at people Used a weapon or force to make someone give you money or things Physically hurt or threatened to hurt someone to get them to have sex with you Waves 2-9

	Add Health Measurement	RYDS Measurement
...Appendix A continued...		
Gang membership	N/A	<ul style="list-style-type: none"> Since we interviewed you last time, were you a member of a street gang or posse? 0=no; 1=yes Waves 2-9
Gang membership duration	N/A	Number of waves subject reported gang membership, from waves 2-9
Gang membership stability	N/A	<u>Short-term</u> : reported one wave of membership <u>Intermittent</u> : reported multiple waves of membership with one or more breaks <u>Stable</u> : reported multiple consecutive waves of membership; did not exit gang more than once Waves 2-9

Appendix B

RYDS Observed Variables Descriptive Statistics

	<i>N</i>	Mean	SD	Range
Indicators in First-Order Factor Analysis ^a				
<i>Depression</i> [$\alpha = .82$]				
Since we interviewed you last time, how often did you:				
Feel you had trouble keeping your mind on what you were doing?	804	2.78	0.86	1 - 4
Feel depressed or very sad?	803	2.45	0.88	1 - 4
Feel bothered by things that don't usually bother you?	804	2.44	0.88	1 - 4
Not feel like eating because you felt upset about something?	804	2.24	1.00	1 - 4
Think seriously about suicide?	803	1.21	0.62	1 - 4
Feel scared or afraid?	804	2.04	0.93	1 - 4
Toss and turn when you slept?	795	2.15	1.06	1 - 4
Feel that you talked less than usual?	803	2.42	1.06	1 - 4
Feel nervous or stressed?	803	2.12	0.97	1 - 4
Feel lonely?	803	1.95	0.95	1 - 4
Feel people disliked you?	803	2.02	0.93	1 - 4
Feel you enjoyed life? (R)	803	1.43	0.64	1 - 4
<i>Low self-esteem</i> [$\alpha = .77$]				
In general, you are satisfied with yourself. (R)	804	1.64	0.59	1 - 4
At times you think you are no good at all.	804	1.98	0.75	1 - 4
You feel that you have a number of good qualities. (R)	804	1.70	0.54	1 - 4
You can do things as well as most other people. (R)	804	1.72	0.56	1 - 4
You feel you do not have much to be proud of.	804	1.84	0.69	1 - 4
You feel useless at times.	804	2.08	0.75	1 - 4
You feel that you are at least as good as other people. (R)	804	1.85	0.59	1 - 4
You wish you could have more respect for yourself.	802	2.42	0.86	1 - 4
Feel bothered by things that don't usually bother you?	804	2.10	0.78	1 - 4
Not feel like eating because you felt upset about something?	804	1.64	0.59	1 - 4

	<i>N</i>	Mean	SD	Range
<i>...Appendix B continued...</i>				
<i>Low attachment to parents [$\alpha = .84$]</i>				
You get along well with your _____. (R)	802	1.34	0.59	1 - 4
You feel that you can really trust your _____. (R)	802	1.27	0.56	1 - 4
Your _____ does not understand you.	802	2.20	0.95	1 - 4
Your _____ is too demanding.	801	2.20	1.00	1 - 4
You really enjoy your _____. (R)	802	1.32	0.55	1 - 4
You have a lot of respect for your _____. (R)	801	1.14	0.41	1 - 4
Your _____ interferes with your activities.	802	2.31	0.95	1 - 4
You think your _____ is terrific. (R)	802	1.39	0.60	1 - 4
You feel very angry toward your _____.	802	1.93	0.89	1 - 4
You feel violent toward your _____.	802	1.32	0.67	1 - 4
You feel proud of your _____. (R)	802	1.32	0.55	1 - 4
<i>Low school connection [$\alpha = .81$]</i>				
Since school began this year, you like school a lot. (R)	800	2.00	0.62	1 - 4
School is boring to you.	800	2.13	0.61	1 - 4
You do poorly at school.	800	1.88	0.55	1 - 4
You don't really belong at school.	800	1.66	0.58	1 - 4
Homework is a waste of time.	800	1.80	0.57	1 - 4
You try hard at school. (R)	799	1.87	0.50	1 - 4
You usually finish your homework. (R)	795	2.05	0.55	1 - 4
Getting good grades is very important to you. (R)	800	1.58	0.55	1 - 4
Sometimes you do extra work to improve your grades. (R)	799	2.15	0.66	1 - 4
If you needed advice on something important, you would go to one of your teachers. (R)	800	2.27	0.69	1 - 4
You feel very close to at least one of your teachers. (R)	800	2.26	0.67	1 - 4
You don't care what teachers think of you.	800	2.11	0.66	1 - 4
You have lots of respect for your teachers. (R)	800	1.86	0.52	1 - 4
Taking everything into account, do you really think you will go to college? (R)	804	1.32	0.63	1 - 3
<i>Negative neighborhood environment [$\alpha = .96$]</i>				
Tell me if each thing is a problem in your neighborhood: [parent report]				
High unemployment?	715	2.02	0.83	1 - 3
Different racial or cultural groups who do not get along with each other?	766	1.36	0.65	1 - 3

	<i>N</i>	Mean	SD	Range
...Appendix B continued...				
Vandalism, buildings and personal belongings broken and torn up?	786	1.77	0.83	1 - 3
Little respect for rules, laws and authority?	784	1.88	0.84	1 - 3
Winos and junkies?	783	1.84	0.88	1 - 3
Prostitution?	749	1.48	0.78	1 - 3
Abandoned houses or burglaries?	793	1.46	0.72	1 - 3
Sexual assaults or rapes?	770	1.45	0.73	1 - 3
Burglaries and thefts?	782	1.80	0.82	1 - 3
Gambling?	732	1.44	0.74	1 - 3
Run down and poorly kept buildings and yards?	794	1.63	0.77	1 - 3
Syndicate, mafia or organized crime?	692	1.26	0.62	1 - 3
Assaults and muggings?	761	1.51	0.76	1 - 3
Street gangs or delinquent gangs?	781	1.66	0.83	1 - 3
Homeless street people?	776	1.37	0.69	1 - 3
Drug use or drug dealing in the open?	772	1.84	0.89	1 - 3
Buying or selling stolen goods?	754	1.66	0.83	1 - 3
<i>Poor academic performance</i>				
[Reverse-coded percentile on math California Achievement Test – official report]	692	49.23	24.14	1 - 99
<i>Parental unemployment</i>				
[Construct measuring whether parent (G1) is unemployed – parent report]	767	0.06	0.24	0 - 1
<i>Public assistance receipt</i>				
[Construct measuring whether parent (G1) receives public assistance – parent report]	768	0.44	0.50	0 - 1
<i>Low self-control^b [mediator] [$\alpha = .81$]</i>				
You sometimes find it exciting to do things even if you might get hurt doing them.	775	2.07	0.78	1 - 4
Excitement and adventure are more important to you than security.	775	1.80	0.61	1 - 4
You lose your temper pretty easily.	775	2.35	0.88	1 - 4
Often when you're angry at people, you feel more like hurting them than talking to them about why you are angry.	775	2.01	0.77	1 - 4
When you are really angry, other people better stay away from you.	775	2.26	0.82	1 - 4
When you have a serious disagreement with someone, it's usually hard for you to talk about it without getting upset.	775	2.43	0.79	1 - 4

		<i>N</i>	Mean	SD	Range
...Appendix B continued...					
Dependent Variables ^c					
<i>Violence Prevalence</i>	[Subject reports engaging in at least one of six violent behaviors – see Appendix A]	804	0.28	0.45	0 - 1
<i>Violence Variety</i>	[Count of the types of violent acts a subject reported committing – see Appendix A]	804	0.42	0.80	0 - 5
<i>Gang Membership</i>	Since we interviewed you last time, were you a member of a street gang or posse?	804	0.12	0.32	0 - 1
<i>Gang Duration</i>	[Number of waves a subject reports gang membership, waves 2-9]	804	0.62	1.25	0 - 8
<i>Gang Stability</i>					
	[Nongang youth, waves 2-9]	573	(71%)		
	[Short-term: one wave of gang membership only, waves 2-9]	101	(13%)		
	[Intermittent: multiple waves of gang membership with a break in between, waves 2-9]	82	(10%)		
	[Long-term: one period of consecutive waves of membership, waves 2-9]	48	(6%)		

^a Variables measured at wave 2 unless noted otherwise.

^b Low self-control variables are measured at wave 10.

^c Dependent variables are measured at wave 3 except for gang duration and stability, which are construct variables.

(R) = reversed item

Note: For dichotomous variables, the mean presents the percentage of respondents coded 1 on that variable. For example, the mean of “gang membership” is 0.14, indicating that 14% of the respondents reported gang membership at wave 2.

Appendix C

Comparisons of RYDS Male and Female SEM Coefficients (z scores)

<i>t</i> wave	W2	W3	W4	W5	W6	W7	W8
<i>Violence Prevalence</i>							
Path A	0.21	-0.12	0.00	0.13	0.70	-0.35	-0.25
Path B	-1.26	-0.46	0.08	-0.61	-0.79	0.92	0.60
Path C	-2.04	-0.46	-1.30	0.00	1.77	-2.30	-1.03
Indirect A-B	-0.86	-0.40	0.00	0.51	-0.51	0.86	0.60
AED total effect	-2.76	-0.69	-1.46	0.24	1.73	-2.39	-0.93
<i>Violence Incidence</i>							
Path A	0.21	-0.12	0.00	0.13	0.58	-0.35	-0.25
Path B	-2.23	-0.55	-2.11	1.80	-2.12	0.00	2.68
Path C	-0.94	0.96	0.00	-1.94	2.23	-2.12	-0.74
Indirect A-B	-1.41	-0.71	-1.39	1.77	-1.34	-0.32	2.24
AED total effect	-1.56	0.78	-0.75	-1.34	1.66	-2.97	-0.23
<i>Violence Variety</i>							
Path A	0.21	-0.12	0.00	0.13	0.58	-0.35	-0.25
Path B	-1.74	-0.83	-0.09	0.92	-1.07	0.49	0.38
Path C	-1.60	0.17	-1.28	-0.57	2.06	-1.99	-0.69
Indirect A-B	-1.66	-0.80	0.00	1.00	-0.60	0.40	0.45
AED total effect	-2.00	-0.18	-1.48	-0.18	1.97	-2.22	-0.66
<i>Gang Membership</i>							
Path A	0.21	-0.12					
Path B	-1.58	-2.28					
Path C	0.49	3.37					
Indirect A-B	-1.20	-1.64					
AED total effect	0.08	2.95					
<i>Violence Prevalence Cross-Lagged</i>							
AED _{<i>t</i>} → AED _{<i>t+1</i>}	-1.66	1.96	-0.89	0.73	1.26	-0.28	
AED _{<i>t</i>} → Violence _{<i>t+1</i>}	-2.70	2.87	-1.63	1.34	1.36	-2.38	
Violence _{<i>t</i>} → AED _{<i>t+1</i>}	-0.83	0.00	-0.14	0.99	-1.94	0.83	
Violence _{<i>t</i>} → Violence _{<i>t+1</i>}	0.87	-2.01	0.91	-0.45	0.00	0.63	
<i>Gang Membership Cross-Lagged</i>							
AED _{<i>t</i>} → AED _{<i>t+1</i>}	0.55	1.11					
AED _{<i>t</i>} → Gang _{<i>t+1</i>}	0.48	3.13					
Gang _{<i>t</i>} → AED _{<i>t+1</i>}	-0.30	0.32					
Gang _{<i>t</i>} → Gang _{<i>t+1</i>}	-0.46	-0.37					

Note: Bold type indicates z scores that are less than -1.96 or greater than 1.96, allowing for rejection of the null hypothesis of no difference between the male-only coefficients and the female-only coefficients.